



US 40 Fraser

Traffic Report

July 2020

CDOT Region 3

Document history and status

Revision	Date Issued	Approved?	Issued to	Change Status
0	04/07/2020	N/A	Town of Fraser, Grand County, CDOT	For review & comment
1	05/29/2020	N/A	Town of Fraser, Grand County, CDOT	Final Document
2	07/01/2020	Yes	Town of Fraser, Grand County, CDOT	Final Version

Project No: WXXX8605
Document Title: US 40 Fraser Traffic Report Draft
Document No.: PPS0217201439DEN
Revision: 2
Date: July 2020
Client Name: CDOT Region 3
Project Manager: Kurt Kolleth
Author: Jacqueline Dowds Bennett
File Name: US40_Fraser_Traffic Report_July2020

Jacobs Engineering Inc.

9191 South Jamaica Street
Englewood, Colorado 80112
United States
T +1.303.771.0900

www.jacobs.com

© Copyright 2020 Jacobs Engineering Inc. The concepts and information contained in this document are the property of Jacobs. Use or copying of this document in whole or in part without the written permission of Jacobs constitutes an infringement of copyright.

Limitation: This document has been prepared on behalf of, and for the exclusive use of Jacobs' client, and is subject to, and issued in accordance with, the provisions of the contract between Jacobs and the client. Jacobs accepts no liability or responsibility whatsoever for, or in respect of, any use of, or reliance upon, this document by any third party.

Table of Contents

- Acronyms and Abbreviations..... ix**
- 1. Introduction 1-1**
- 2. Data Collection..... 2-1**
 - 2.1 Traffic Counts2-1
 - 2.1.1 Summer Counts.....2-1
 - 2.1.2 Winter Counts2-4
 - 2.2 Existing Conditions Information2-5
 - 2.3 Volume and Growth Data.....2-5
 - 2.4 Planned Developments2-6
 - 2.4.1 Access Permit Documents2-6
 - 2.4.2 Traffic Impact Studies2-6
 - 2.4.3 Downtown Fraser Strategic Plan2-6
 - 2.4.4 Clark Lipscomb Correspondence and Documentation.....2-6
 - 2.4.5 Local Agency Staff.....2-7
- 3. Operations Analysis and Forecasting Methodology 3-1**
 - 3.1 Analysis Conditions and Scenarios3-1
 - 3.2 Existing Conditions Model3-2
 - 3.3 Forecast Future Travel Demand3-2
 - 3.4 Future Conditions Models.....3-3
 - 3.4.1 Year 2022 Existing Plus Committed Interim Model.....3-3
 - 3.4.2 Year 2045 No Build Model.....3-4
 - 3.4.3 Year 2045 Build Models without the Fraser Valley Parkway.....3-4
 - 3.4.4 Capacity Assessment Sensitivity Test3-4
 - 3.5 Measures of Effectiveness.....3-5
- 4. Analysis Volumes4-1**
 - 4.1 Analysis Peak Hour.....4-1
 - 4.2 Annual Growth Rates.....4-1
 - 4.2.1 Vehicles.....4-2
 - 4.2.2 Bicycles and Pedestrians.....4-3
 - 4.3 Heavy Vehicle Percentage4-3
 - 4.4 Year 2019 Existing Conditions Volumes4-4
 - 4.5 Year 2022 Existing Plus Committed Conditions Scenario Volumes4-4
 - 4.6 Year 2045 No Build and Build Scenarios.....4-12
 - 4.6.1 Lift Operations Center Development.....4-15
 - 4.6.2 Downtown Fraser Developments.....4-15
 - 4.6.3 Byers Peak Ranch Development4-21
 - 4.6.4 Grand Park Development4-21
 - 4.6.5 Rendezvous Development.....4-21
- 5. Operations Analysis Results.....5-1**

5.1	Year 2019 Existing Conditions.....	5-1
5.2	Year 2022 Existing Plus Committed Interim Condition.....	5-2
5.3	Year 2045 No Build Scenario	5-4
5.4	Year 2045 Build Scenario with Roundabouts (Alternative 1)	5-6
5.5	Year 2045 Build Scenario with Traffic Signals (Alternative 2).....	5-8
5.6	Comparison of Year 2045 Build Scenarios Alternatives 1 and 2	5-11
5.7	Year 2045 Build Scenario with Refined Traffic Signals Alternative	5-12
5.7.1	Composition of the Refined Traffic Signals Alternative	5-12
5.7.2	Projected Operations.....	5-14
5.7.3	Driveways Between the Lions Ponds and Old Victory Road.....	5-15
5.8	Year 2022 Existing Plus Committed Interim Condition Volumes with Refined Traffic Signals Alternative Roadway Network.....	5-16
5.9	Projected Operations Summary.....	5-16
5.10	Measures of Effectiveness.....	5-18
5.11	Summary of Conditions and Scenarios	5-18
5.12	Level 1 Screening Conclusion.....	5-20
5.13	Considerations for County Road 8 Road Closure.....	5-20
5.14	Capacity Considerations for US 40	5-20
5.15	Signal Warrant Analyses.....	5-21
5.15.1	Eight-Hour Vehicular Volume (Warrant 1)	5-21
5.15.2	Four-Hour Vehicular Volume (Warrant 2)	5-22
6.	Safety and Access.....	6-1
6.1	Summary of CDOT Safety and Operational Analysis Report, August 2019	6-1
6.2	US 40 Access	6-2
6.3	Potential for Refined Traffic Signals Alternative to Address Safety and Access Needs	6-3
7.	Conclusions and Recommendations.....	7-1
7.1	Short-term Recommendations	7-1
7.2	Long-term Recommendations	7-3
8.	References.....	8-1

Appendixes

- A Traffic Count Data
- B Travel Time Data Collection Field Logs
- C US 40 Fraser – Existing Access Book
- D Vissim Calibration Process
- E Operations Analysis Results
- F Signal Warrant Analysis Volumes
- G Fraser Valley Parkway Assessment

Tables

1	Level of Service Thresholds.....	3-5
2	Year 2022 Existing Plus Committed Interim Scenario Trip Generation and Distribution Assumptions	4-9
3	Year 2045 Trip Generation and Distribution Assumptions	4-18
4	Year 2019 Existing Scenario Level of Service Results.....	5-1
5	Year 2022 Existing Plus Committed Interim Condition Level of Service Results	5-3
6	Year 2045 No Build Scenario Level of Service Results	5-5
7	Year 2045 Build Scenario with Roundabouts Level of Service Results	5-6
8	Year 2045 Build Scenario with Traffic Signals Level of Service Results	5-10
9	Year 2045 Build Scenario with Refined Traffic Signals Level of Service Results	5-15
10	Year 2022 Existing Plus Committed Interim Condition with Refined Traffic Signals Alternative Roadway Network Level of Service Results.....	5-16
11	Intersection Delay and Level of Service Summary	5-17
12	Refined Traffic Signals Alternative System-wide Measures of Effectiveness	5-18

Exhibits

1	Study Area	1-2
2	CDOT (2018) Typical Traffic Analysis and Forecasting Process Flowchart	1-3
3	Summer Traffic Count Collection Locations.....	2-2
4	2019 Existing Summer Traffic and Trail Counts	2-3
5	Eastbound Daily Count Comparison.....	2-4
6	Year 2019 Existing Peak Hour Traffic and Trail Volumes	4-5
7	2022 Existing Plus Committed Peak Hour Traffic and Trail Forecasts.....	4-6
8	Year 2022 Average Daily Traffic Composition.....	4-7
9	2022 Peak Hour Trip Generation Estimates	4-8
10	2045 Peak Hour Traffic & Trail Forecasts Without Fraser Valley Parkway	4-13
11	Year 2045 Average Daily Traffic Composition.....	4-14
12	2023 Through 2045 Peak Hour Trip Generation Estimates	4-16
13	Year 2045 Build Condition Proposed Roadway Network.....	4-18
14	Proposed Access Points from Victoria Village and Riverwalk District Developments to US 40 ...	4-20
15	Year 2045 Build Scenario with Roundabouts Alternative Roadway Network	5-7
16	Year 2045 Build Scenario with Traffic Signals Alternative Roadway Network	5-9
17	MUTCD Table 4C-1, Eight-Hour Vehicle Volume Warrant	5-23
18	MUTCD Figure 4C-1, Four-Hour Vehicle Volume Warrant	5-23

Acronyms and Abbreviations

>	greater than
≤	less than or equal to
%	percent
ADT	Average Daily Traffic
ATR	Automatic Traffic Recorder
BPR	Byers Peak Ranch
CDOT	Colorado Department of Transportation
CR	County Road
CSS	Context Sensitive Solutions
EB	eastbound
FHU	Felsburg Holt & Ullevig
FHWA	Federal Highway Administration
HCM	<i>Highway Capacity Manual 6th Edition</i>
ITE	Institute of Transportation Engineers
LED	Light Emitting Diode
LLC	Limited Liability Corporation
LOS	level of service
LOSS	level of service of safety
MOE	measure of effectiveness
MP	milepost
MUTCD	<i>Manual on Uniform Traffic Control Devices</i>
OTIS	Online Transportation Information System
PA	Planning Area
PLT	Project Leadership Team
RIRO	right-in/right-out
RV	recreational vehicle
sec/veh	second(s) per vehicle
SF	square feet
Strategic Plan	<i>2017 Downtown Fraser Strategic Plan</i>
TIS	Traffic Impact Study
TMOSS	Terrain Modeling Survey System
TripGen	ITE Trip Generation web-based app
TWSC	two-way stop control
US	United States [highway]

VHT	vehicle hours traveled
VMT	vehicle miles traveled
WB	westbound

1. Introduction

The Colorado Department of Transportation (CDOT) Region 3 initiated a project to take a multidisciplinary approach and partner with local stakeholders to identify a problem statement, establish criteria and define success factors to widen U.S. Highway 40 (US 40) from two to four general purpose lanes from the Eisenhower Drive intersection to the Rendezvous Road intersection in the Town of Fraser in Grand County, Colorado. After the project began, discussions with local stakeholders led to expanding the study area west to the County Road 5 (CR 5) intersection with US 40. This expansion was deemed necessary to provide a comprehensive assessment of and recommendations for improvements to US 40 through Fraser. **Exhibit 1** shows the study area, which is approximately 2.6 miles long between milepost 226.3 and 228.9.

The primary goal of this project is to develop both short- and long-term alternatives and identify Proposed Actions for reducing congestion, improving operational performance and addressing future transportation needs along US 40 between Rendezvous Road and CR 5. The Context Sensitive Solutions (CSS) 6-Step process endorsed by the Project Team included a traffic study that analyzed various alternatives and recommendations for a US 40 corridor-wide preferred alternative to include highway widening and associated intersection improvements. Conducting this traffic study necessitated forecasting future volumes that account for background growth and anticipated development. The purpose of this report is to document the traffic study and recommendations. This traffic analysis served as the Level 1 screening within the CSS process to identify one preferred US 40 corridor-wide roadway configuration including intersection traffic control measures that will be advanced to the Level 2 screening process. In the Level 2 screening process, the advanced alternative will undergo an impact analysis and more refinement to identify the preferred alternative.

The Town of Fraser and Grand County sponsored an additional task to assess the study area with the addition of the proposed Fraser Valley Parkway. This facility is generally proposed to be 0.25 to 0.5 mile west of US 40 and extends between the Kings Crossing Road intersection with US 40 and the Town of Tabernash. The intent of this task was to estimate the potential change in traffic operating conditions on US 40 with a parallel facility in the roadway network and determine if these operational changes suggest the scope of the US 40 preferred alternative could be reduced in magnitude. The change in operating conditions would result from a diversion of traffic demand from US 40 to the Fraser Valley Parkway. The work associated with Fraser Valley Parkway assessment is included as **Appendix G** of this report.

This project followed the process depicted in **Exhibit 2**, which is Figure 12 from the Quick Start Guide in the CDOT 2018 *Traffic Analysis and Forecasting Guidelines* document. The rest of this report includes chapters that document the conduct of each step in this flowchart.



LEGEND

- +++ UPRR Railroad
- Fraser to Winter Park Trail
- Sidewalk

Exhibit 1. Study Area
 CDOT Region 3
 US 40 – Fraser

Figure 12: Typical Traffic Analysis and Forecasting Process Flowchart

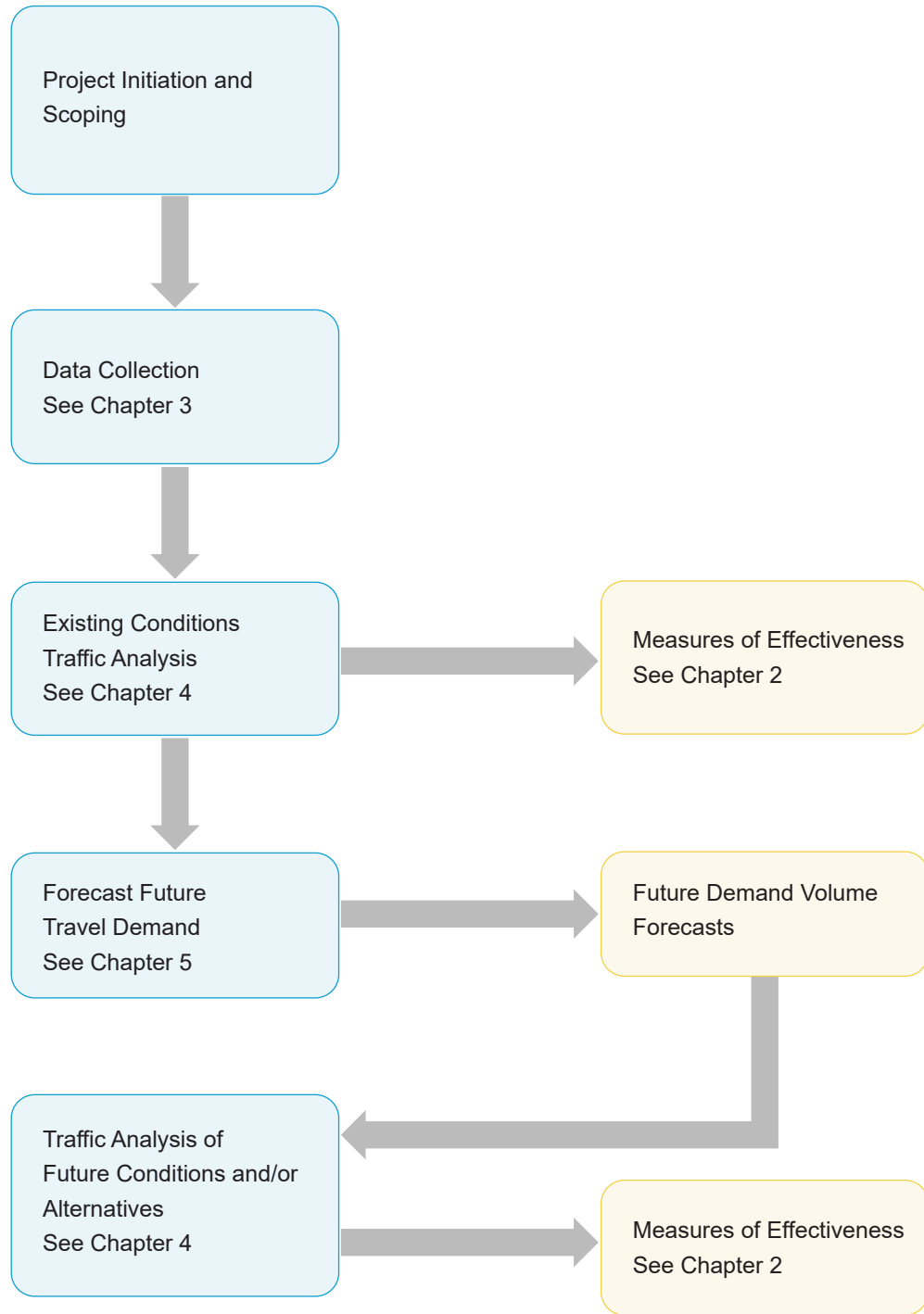

Exhibit 2. CDOT (2018) Typical Traffic Analysis and Forecasting Process Flowchart

2. Data Collection

Data and information were collected from several sources to gain the most comprehensive understanding possible of the existing conditions in the study area and to identify the projected future conditions based on planned development. This chapter describes the data collection effort and sources.

2.1 Traffic Counts

2.1.1 Summer Counts

A July Saturday was selected for traffic counting to represent a peak demand period. The CDOT Online Transportation Information System (OTIS) data from the closest Automatic Traffic Recorder (ATR) suggest July is the highest volume month. Anecdotal evidence suggests Saturday is the peak volume day of the week. Therefore, traffic counts were collected on Saturday July 13, 2019, through Fraser and Grand County. Daily counts by vehicle classification were collected at each end of the study area in 15-minute intervals. Vehicle turning movement and bicyclist/pedestrian crossing counts were collected along with peak hour factors at ten intersections for 2 hours each in the morning (between 8 and 10 a.m.), noon (12 to 2 p.m.), and evening (4 to 6 p.m.) time periods. Bicyclist/pedestrian counts were also collected at three trail locations adjacent to US 40 during these same 6 hours. **Exhibit 3** shows the count locations. **Appendix A** contains the raw count data.

Exhibit 4 summarizes the data collection effort. The daily volumes were approximately 18,800 vehicles on the east end of the study corridor near the Fire Station access and 14,600 vehicles on the west end near CR 5. The three hours (9 to 10 a.m., 12:15 to 1:15 p.m., and 4 to 5 p.m.) represent the peak 60-minute period at the County Road 72/County Road 804 (hereafter referred to as CR 72) intersection. These particular time periods are not necessarily reflective of the peak 60-minute periods at the other data collection locations. The exhibit also summarizes the bicycle and pedestrian crossing volumes at intersections and at three locations along the regional trail.

CR 72 has the highest vehicle volumes of any of the cross streets, which is indicative of several factors that result in this being the highest-volume intersection in the study area. There are few locations in the corridor at which US 40 can be crossed in both directions; of these locations, CR 72 is the only continuous street on both sides of the highway. CR 72 provides access to several businesses and residential developments on both the north and south sides of US 40. As the only signalized intersection near the downtown core area, this location is appealing to drivers to cross or turn to and from the highway. This is one of two locations in the study area with provisions for bicycle/pedestrian crossing with dedicated signal phasing (Rendezvous Road is the other location).

The County Road 8 (CR 8) bridge over the Fraser River, which is located approximately 0.25 mile north of US 40 was under construction on this data collection day. Therefore, the road was closed and volume from an adjacent neighborhood to the north was rerouted to the CR 72 intersection for access to US 40. Because this intersection was also counted on this day, all the typical demand volume between US 40 and the neighborhood was captured in the counts. However, the distribution of the turn movements through these two intersections and the through volumes on US 40 between CR 72 and CR 8 as shown in **Exhibit 4** varies slightly from the typical patterns as a result of the road closure.



Exhibit 3. Summer Traffic Count Collection Locations

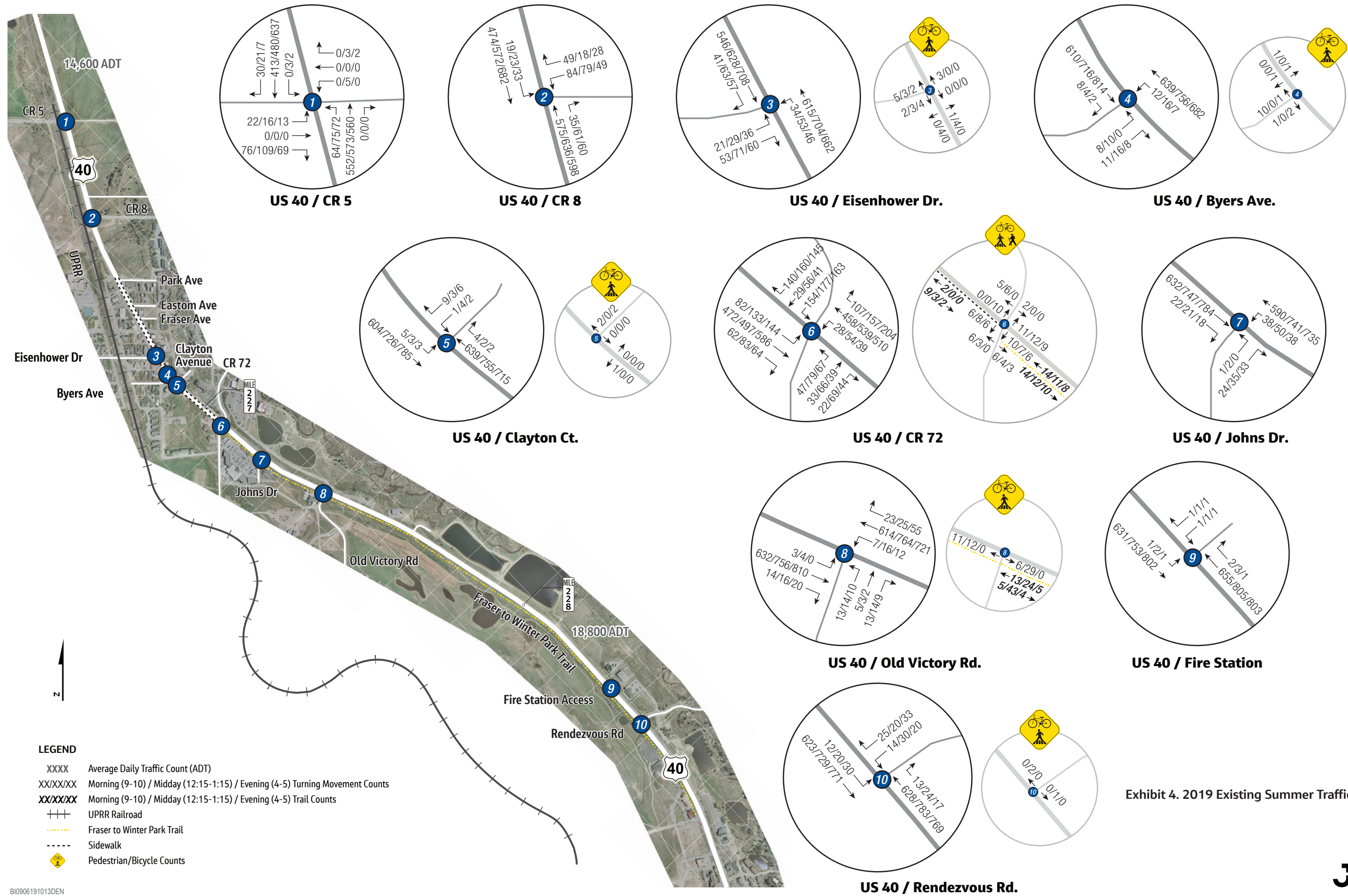

Exhibit 4. 2019 Existing Summer Traffic & Trail Counts
 CDOT Region 3
 US 40 - Fraser

2.1.2 Winter Counts

Winter counts were collected on Saturday, January 18, 2020, to determine if the preferred alternative as developed based on the summer demand would be adequate to accommodate the winter demand. Daily counts were collected at the same two locations included in the July 13, 2019, data collection effort to analyze seasonal count variations. Turning movement counts were collected during the 12:15 p.m. to 1:15 p.m. hour at the US 40/CR 72 and Wapiti Drive/CR 72 intersections. The US 40 intersection counts were collected along with the daily counts for comparison to the summer counts. The Wapiti Drive intersection was counted to support the addition of this intersection to the final analysis scenario. Approximately 730 vehicles traveled through the intersection during this hour. The volumes indicate the primary travel pattern is through movement between US 40 and development to the north of this intersection, followed by turn movements to access the Safeway shopping center. Minimal volume travels across CR 804 between the Safeway shopping center and the one-way frontage road that intersects with US 40 at Old Victory Road.

At the US 40 intersection with CR 72, similar counts for each 15-minute period indicate fairly consistent arrival patterns during the hour. The total volume through the intersection of 1,660 vehicles is 20 percent less than the 2,070 vehicles counted in the summer during this hour. The demand to the north is approximately 55 percent greater than to the south of US 40, which is the same pattern observed in the summer counts.

The daily count for the location just west of the Fire Station access was 18,500 vehicles. This count is very similar to the summer count of 18,800 vehicles at this location. At the west end of the study area, near CR 5, the winter daily count was 11,000, which was 33 percent less than the summer count of 14,600 daily vehicles. Like the summer counts, this difference in average daily traffic indicates the higher demand is within and to the east of Fraser rather than regional movement through the study area. Thus, the data indicate a greater proportion of traffic originates in Fraser in the winter than in the summer, suggesting more people stay within Fraser and access Winter Park during the winter than the summer. **Exhibit 5** graphically compares the eastbound daily volumes counted in the summer and winter near the Fire Station access as vehicles exit Fraser.

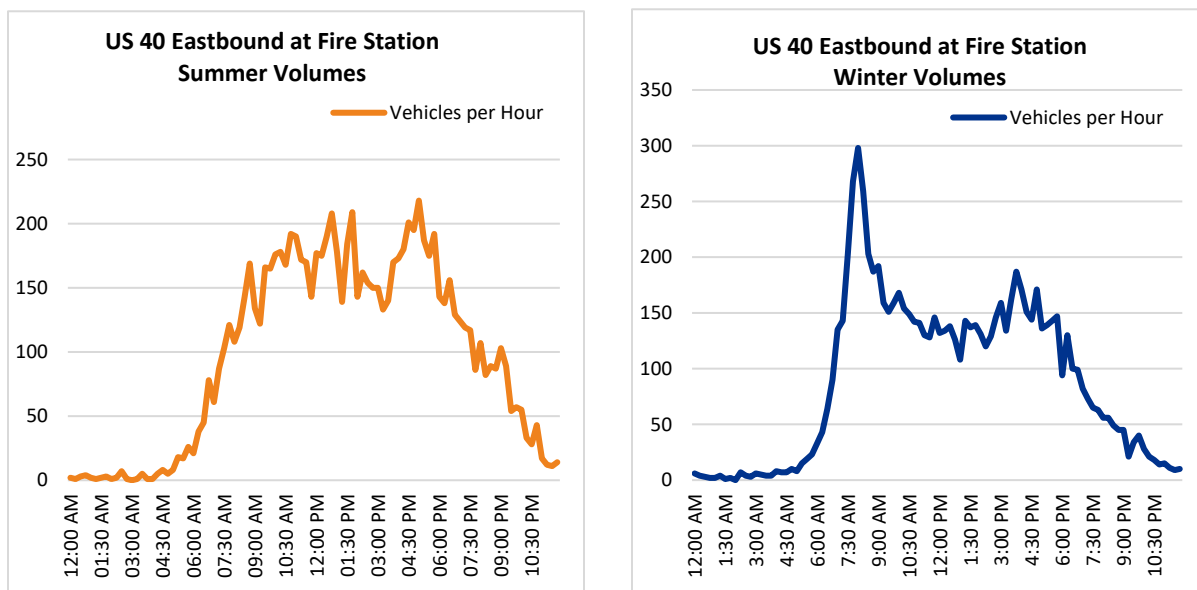

Exhibit 5. Eastbound Daily Count Comparison

The eastbound spike in the morning traffic is more pronounced in the winter volumes compared to the summer, which is more evenly distributed during the late morning to afternoon time frame. This spike is perhaps attributable to skiers destined for Winter Park; a corresponding increase is noticeable in the westbound direction during the afternoon hours between 4 and 5 p.m.

The analysis concluded the summer volumes are higher and can account for the winter volumes. Therefore, traffic modeling or alternatives development based on summer counts and forecasts do not need to be revised to accommodate winter volumes.

2.2 Existing Conditions Information

Development of the conceptual layouts for the alternatives and the operations models required information about the following elements:

- Existing lane widths.
- Speed limits.
- Roadway curvature.
- Intersection geometrics.
- Access control.
- Parcel ownership.
- Signalized/unsignalized traffic control.
- Signal timing.
- Travel times.

The geometric and intersection control data were collected through a combination of coordination with CDOT staff, field visits, review of Terrain Modeling Survey System (TMOSS) data, aerial mapping, right-of-way and as-built plans. Access permits approved by CDOT provided information about parcel ownership, land uses, existing access locations and types, and new access locations and types to US 40.

Existing performance data for travel time and operating speed were collected by Fraser staff using the floating car method for six runs in each direction on US 40. The data were collected on Saturday, September 9, 2019, during the 12:15 to 1:15 pm hour, to simulate the analysis peak hour. The data indicate that on this day, the travel time in the westbound direction varied between 2.1 and 3.5 minutes, while travel times in the eastbound direction were slightly longer, between 3.5 and 4.3 minutes.

Appendix B contains the field data logs.

2.3 Volume and Growth Data

Monthly volume data for the closest ATR near Berthoud Pass were gathered from OTIS. These data assisted in determining July was the peak volume demand month in the year and in the summer season, and February was the peak volume demand month in the winter season (the January volume demand was approximately 50 vehicles lower than February, so effectively the same demand). The 20-year growth factor for US 40 was also obtained from OTIS to assist with determination of a vehicular growth rate. Other information used in the determination of a vehicular growth factor was obtained from the Northwest Transportation Planning Region's Regional Transportation Plan (2015) and recent traffic impact studies (TISs) completed for local developments at Byers Peak Ranch and Riverview Townhomes. Estimated Grand County population projections for use in determining a bicyclist/pedestrian growth rate were gathered from the state demographers office website.

2.4 Planned Developments

CDOT and the Fraser and Grand County planning departments provided information about proposed developments and their likely density, along with previous transportation studies and comprehensive plans produced for the area.

2.4.1 Access Permit Documents

CDOT provided 45 documents related to access applications that have been approved by Region 3. The documents included access permit applications and, in some cases, construction plans. Information gleaned from this documentation included parcel ownership, land uses, projected peak hour volumes to be generated by developments, implementation years, and the new right-in/right-out (RIRO) access location to US 40 for the Meadows at Grand Park development. CDOT Access Permits documentation was referenced to produce the US 40 Fraser – Existing Access Book. Contained in **Appendix C**, this book is a summary of the existing and potential future access conditions.

2.4.2 Traffic Impact Studies

CDOT and the Towns of Fraser and Winter Park provided traffic impact study documentation for planned and/or approved developments. These documents were an essential source for determining which developments and phases of developments would be in each scenario analyzed during this study. Likewise, land uses and related quantities were obtained from these documents along with the trip distributions to US 40 and Fraser Valley Parkway used in the forecasting process. These documents also provided information about additions to the roadway network. Documents on the following areas and developments were referenced to obtain information used in this traffic study:

- Arrow at Winter Park (May 2016).
- Byers Peak Ranch (May 2019).
- Cornerstone Planning Area 1WA (March 2005).
- Grand Park (January 2013).
- Lift Operations Center (February 2019).
- Rendezvous (December 2004).
- Riverview Townhomes (May 2019).
- Roam (April 2019).
- South Sitzmark Parcel (April 2017).
- US 40 Corridor (August 2012).

2.4.3 Downtown Fraser Strategic Plan

Information was gathered from this plan for the proposed Riverwalk, Victoria Village, and Poleyard developments regarding land uses and access locations to US 40. As this plan was conceptual in nature and did not provide the level of detail necessary for estimating trip generation, Town of Fraser staff provided assumptions for size of developments, land uses, and residential densities.

2.4.4 Clark Lipscomb Correspondence and Documentation

Clark Lipscomb is a local developer in the local area and the primary contact for the Grand Park Development company. He provided several pieces of documentation and participated in correspondence with the study team to assist with gaining an understanding of completed and planned development. One document was an illustration that shows aerial mapping overlaid with graphics that depict completed and planned developments. This illustration includes tables that aggregate the developments by parcel and

list specific land uses and densities or units for each parcel. Mr. Lipscomb also added notes to the exhibit to identify development that has occurred or is in process. These notes were used to assist with defining the interim analysis scenario.

In addition, Mr. Lipscomb provided a page from the annexation agreement entitlement documentation that listed the land use, average density, acreage, and maximum number of units or square footage per planning area in the Grand Park development. These data were used along with the data about completed and in-process developments to help define the Year 2022 Existing Plus Committed Interim Condition and the ultimate 2045 Build scenario. Mr. Lipscomb also provided computer aided design files that were used to include the graphics for the planned developments in the exhibits for this report.

2.4.5 Local Agency Staff

Town of Fraser staff provided information about approved developments and anticipated years of implementation as well as providing direction for the types of land uses and associated densities to use in estimating the trip generation for the three development districts included in the Downtown Fraser Strategic Plan. Staff also provided information on the proposed Fraser Valley Parkway alignment, trail connections and pedestrian crossing locations for US 40, proposed roadway network improvements adjacent to US 40, and the history of the Safeway frontage road. Grand County staff also provided direction about the proposed Fraser Valley Parkway alignment and roadway connections to the existing network for the Byers Peak Ranch development. Town of Winter Park staff provided information about the status of the developments included in the traffic impact studies and the status of ongoing additions to the road network to include the Grand Park Drive grade-separated railroad crossing.

3. Operations Analysis and Forecasting Methodology

This chapter describes the methodology followed to develop volumes and analyze traffic operations for various scenarios that depict the range of alternatives in each analysis year. The traffic analysis methodology aligns closely with the guidance in the CDOT 2018 *Traffic Analysis and Forecasting Guidelines* document.

Vissim microsimulation modeling software is the preferred tool for this traffic analysis because it provides the opportunity to incorporate traditional traffic signal and roundabout intersections along with non-automobile travel modes into one corridor model. One comprehensive model that measures performance against one set of criteria provides consistency and eliminates the need for multiple tools that use varying methodologies to assess different aspects of the corridor such as intersection configurations and multi-modal users. This microscopic tool can also be used to develop visualizations for use with stakeholders and other interested parties to assist with explaining the alternatives development and analysis results. In the future, the model developed for this project can be augmented to extend west or east along the corridor to achieve a comprehensive corridor-wide planning tool.

3.1 Analysis Conditions and Scenarios

The traffic analysis includes the following four scenarios:

- **Year 2019 Existing Conditions:** This scenario represents the existing roadway network, signal timing, and traffic counts with refinements to balance between intersections.
- **Year 2022 Existing Plus Committed Interim Condition:** This scenario reflects the roadway network improvements and developments that are anticipated to be complete by or within year 2022. The peak hour volumes represent the sum of the forecasted background and development-generated volumes. This scenario includes the same geometric and intersection traffic control configurations and access points as the Year 2019 Existing Conditions plus the approved RIRO access to eastbound US 40 for the Meadows development.
- **Year 2045 No Build Scenario:** This scenario reflects the developments that are anticipated to be complete by or within year 2045. The year 2045 was selected to represent the future horizon planning year to be consistent with the current horizon planning year in CDOT's statewide travel demand model. The year 2045 vehicular peak hour volumes for this scenario are the sum of the forecasted background and development-generated volumes. To accommodate the developments, the roadway network adds a fourth approach for the Rendezvous Road intersection and a full-movement, unsignalized intersection between Old Victory Road and the Fire Station access to the Year 2022 Existing Plus Committed network.
- **Year 2045 Build Scenarios:** Different models were developed from the Year 2045 No Build roadway network to reflect the differences in the type of intersection control between the alternatives. The year 2045 peak hour volume forecast is the same for the no build and build scenarios. This assumption was necessary because the applied factor method used to forecast the future volumes is not a dynamic process and the process does not account for varying travel patterns based on driver preferences, such as delay tolerances and type of intersection control.

3.2 Existing Conditions Model

To assess existing roadway and intersection capacity, a Vissim microsimulation model was constructed to represent one peak hour in the corridor. This peak hour was collectively determined with CDOT to be a Saturday noon hour based on the traffic count results. The Year 2019 Existing Conditions model encompasses US 40 and its primary intersections with CR 5, CR 8, Eisenhower Drive, Byers Avenue, Clayton Court, CR 72, Johns Drive, Old Victory Road, Fire Station access, Rendezvous Road, and driveways between these cross roads. In addition, bicycle and pedestrian movements that cross US 40 at the Post Office, Crooked Creek Saloon and Byers Avenue were included in the model. The input volumes for this model reflect refinement to the collected traffic counts to balance volumes between intersections. The model incorporates the existing posted speed limits.

The Year 2019 Existing Conditions model was calibrated to field conditions using Federal Highway Administration and CDOT Measures of Effectiveness (MOEs) for travel times, travel speeds, and volume throughput per the targets established in Table 10 in the CDOT 2018 *Traffic Analysis And Forecasting Guidelines* document. The travel time calibration was accomplished by comparison to travel times collected manually during a field visit (floating car method) on a September Saturday in 2019. Likewise, the volume throughput calibration verification was accomplished by comparison to the count data collected on July 13, 2019. **Appendix D** contains a spreadsheet that summarizes the calibration process for these MOEs.

Because the MOEs were not met with the initial model default settings, the desired speed distribution, car following factors such as safety distance factors, and lane change distance model parameters were adjusted iteratively within the acceptable ranges until the targets were met for travel time, travel speed and volume throughput for the 2019 existing conditions. Once the parameters were adjusted, the existing conditions model was run ten times with random seeds. Only ten runs were required to achieve the minimal standard deviation for model results that simulate the typical Saturday midday peak hour in the study corridor. The calibration effort was completed prior to using the existing conditions model to create the models for the future scenarios.

3.3 Forecast Future Travel Demand

The future planning year is 2045, to match the horizon year for the CDOT Statewide Travel Forecasting Model. Rather than a travel demand modelling effort, the forecasting effort was a sketch planning effort that incorporated elements from both the factor method and the trip generation/distribution method. The following steps were followed to develop volumes for the traffic operations analyses:

- **Step 1.** Starting with the traffic counts collected and refined as part of this project, the factor method was used to apply a fixed-rate growth factor through the year 2045 to forecast the future background traffic volumes. This one set of forecast background volumes is applicable to both the future no build and build scenarios. Turning movement volumes for other intersections that were included in the operations analysis but were not part of the data collection effort/post-processing routine were determined through a hand assignment/balancing process.
- **Step 2.** Using the trip generation/distribution method, additional volume to account for anticipated and potential developments was added to the forecasted background volumes to forecast the total no build and build scenario volumes for daily traffic and the analysis peak hour. The daily volumes were reported but not used in the analysis. The peak hour volumes were forecast by turning movement at the intersections for use in the analyses.

- Approved traffic impact study and Entitlement Agreement documentation was referenced to determine the land uses and associated sizes/units associated with these additional volumes. For the parcels that are not currently addressed with an approved traffic impact study or analysis, the Institute of Transportation Engineers (ITE) *Trip Generation Manual, 10th Edition*, and Trip Generation (TripGen) web-based app were used to predict future traffic demand for these parcels. This effort consisted of identifying the appropriate generic land uses, determining the trip generation, and distributing or assigning the increase in traffic to the existing and future street system. The distribution was estimated through consultation with Town staff and also based on assumptions that included reference to existing traffic volume proportions and to distributions in the approved traffic impact studies or analyses. The traffic impact studies referenced for the development-generated volumes present weekday morning and evening peak hour volumes; the evening peak hour volumes were used to forecast the total analysis volumes. The evening peak hour is likely to be more representative of the Saturday mid-day peak hour because, per the ITE Trip Generation Manual, the evening peak hour reflects a more balanced enter/exit ratio than the morning peak hour, which is typically skewed toward exit volumes for residential developments.
- **Step 3.** The growth rate determined in **Step 1** was applied to the collected and refined counts to obtain year 2022 peak hour background forecast volumes for the Year 2022 Existing Plus Committed Interim scenario analysis peak hour. The development-generated volumes determined in **Step 2** for the developments anticipated to be complete by year 2022 were added to the forecasted background volumes to forecast the peak hour analysis volumes. The forecasts resulting from this step did not include the Fraser Valley Parkway.
- **Step 4.** The development-generated volumes determined in **Step 2** for the developments anticipated to be complete by year 2045 (including the developments complete by 2022) were added to the 2045 forecasted background volumes developed in **Step 1** to forecast the horizon year 2045 peak hour analysis volumes. The forecasts resulting from this step did not include the Fraser Valley Parkway.
- **Step 5.** The demand volume that the preferred alternative could service with level of service (LOS D) operations in the peak hour was forecast for use in determining an interim year in which additional improvements would be required to service the demand. To forecast this volume, the year 2045 forecast volumes entering the study area were incrementally reduced until LOS D was achieved at all intersections in the study area. This was a global adjustment by the same percent reduction rather than localized adjustments to each roadway entering the network.

3.4 Future Conditions Models

The Year 2019 Existing Conditions Vissim model was used as the baseline to develop the Year 2022 Existing Plus Committed Interim Condition model. This model was then used to develop the Future No Build and Future Build models. The same peak hour, performance measures and level of service targets used for the existing conditions were applied to the future conditions analyses.

3.4.1 Year 2022 Existing Plus Committed Interim Model

The Year 2022 Existing Plus Committed Interim model has the same geometric and intersection traffic control configurations and access points as the Year 2019 Existing Conditions model plus the approved RIRO access to eastbound US 40 for the Meadows development. The 2022 interim forecast volumes developed in **Step 3** were the volumes used for this model.

3.4.2 Year 2045 No Build Model

The No Build model has the same intersection traffic control as the Year 2022 Existing Plus Committed model. The roadway network in the eastern portion of the study area is augmented with the addition of a full-movement unsignalized intersection and a fourth approach to the Rendezvous Road intersection as committed to in traffic impact studies. The forecasts developed in **Step 4** were the volumes used for this model. The microsimulation results identified anticipated future congestion and operational deficiencies that informed the development of the build alternatives.

3.4.3 Year 2045 Build Models without the Fraser Valley Parkway

The build models were developed from the no build model to represent the alternatives by revising the type of traffic control for the County Roads 5, 8, and 72 intersections. In all three models, the Eisenhower and Old Victory Roads intersections are also signalized. The access locations to US 40 are the same as in the Future No Build model. The following three Vissim models were developed to represent the range of build alternatives without the Fraser Valley Parkway:

- Roundabouts for the County Roads 5, 8, and 72 intersections.
- Traffic signals for the County Roads 5, 8, and 72 intersections.
- Refined version of the traffic signal alternative to optimize timing and test other operational improvements.

These traffic models included elements at the other intersections between Rendezvous Road and CR 5 in the Vissim model to address operational and safety issues identified from the Year 2022 Existing Plus Committed Interim Condition and the No Build Vissim results. The forecasts developed in Step 4 for the No-Build scenario were the traffic and pedestrian/bicyclist volumes used for the build scenarios without the Fraser Valley Parkway alternative. The traffic and pedestrian/bicyclist volumes were the same in these three build models to assess the operational differences between the two types of traffic control (traffic signal versus roundabout) at the three intersections.

A deterministic analysis was completed using Sidra Intersection for the roundabout representing the CR 72 intersection with US 40 to determine if a roundabout can process the forecasted volume demand. Comparison of the results to those obtained from Vissim did not suggest any adjustments needed to be made to the Vissim parameters.

3.4.4 Capacity Assessment Sensitivity Test

The Capacity Assessment Sensitivity Test was conducted to determine an interim year between the Year 2022 Existing Plus Committed Interim Condition and the Year 2045 No Build/Build Scenarios for which options for serving additional volume demand would need to be implemented. Future Year model has the same geometric and intersection traffic control configurations and access points as the final 2045 Build model without the Fraser Valley Parkway. An annual growth rate was calculated using the total volume forecasts for years 2022 and 2045. This growth rate was then applied to the year 2022 forecast volumes until the LOS D volumes determined in **Step 5** were reached. The volumes were then grown through additional years to determine the first year in which the LOS D could not be maintained; this year was determined to be the future year for the capacity assessment analysis. This process assumes a linear growth rate for the development, which is not likely to be the case. However, there was no other information available at the time this analysis was conducted about development implementation timeframes.

3.5 Measures of Effectiveness

Traffic conditions were analyzed for one peak hour which was collectively determined with CDOT to be a Saturday noon hour. The existing and future traffic operating conditions were defined with MOEs obtained from running the Vissim model and post-processing the results. As determined in coordination with CDOT, system-wide MOEs are total network delay, vehicle miles traveled (VMT), and vehicle hours traveled (VHT). Suggested location-specific MOEs are LOS, control delay, travel time, operating speed, and queue length. These MOEs obtained from the Vissim microsimulation results identify existing congestion and operational deficiencies. These deficiencies help to begin identification of initial improvement strategies. Deficiencies were defined as operating characteristics that don't meet the desired MOEs.

Intersection LOS was based on node delay calculations from the Vissim model and resultant level of service determined based on delay thresholds defined by *Highway Capacity Manual 6th Edition* (HCM) methodologies for signalized and unsignalized intersections. The target threshold for acceptable operations is LOS D as defined by the HCM methodologies for signalized and unsignalized intersections and agreed upon with CDOT. **Table 1** shows the average delay in seconds per vehicle for each corresponding letter of service designation. The signalized intersection level of service thresholds were applied for the roundabouts. Based on HCM methodology for signalized intersections, LOS is defined in terms of average delay per vehicle in seconds and is calculated based on traffic volumes, lane geometry, and the signal timing/phasing plan. Delay is reported by individual movement and for the overall intersection. For unsignalized intersections, LOS is defined in terms of average delay per vehicle for the stop- or yield-controlled movements. The method incorporates delay associated with deceleration, acceleration, stopping, and moving up in the queue. For side street stop-controlled intersections, delay is typically represented in seconds for each movement from the minor approaches and the left turns from the major street and is based on the ability of drivers to find a gap in the conflicting traffic stream. Rather than reporting an overall intersection delay, unsignalized intersections report the movement with the highest delay and the corresponding LOS.

Table 1. Level of Service Thresholds

Average Vehicle Delay (seconds/vehicle)	LOS
<i>LOS Thresholds – Unsignalized Intersections</i>	
≤ 10	A
> 10 – 15	B
> 15 – 25	C
> 25 – 35	D
> 35 – 50	E
> 50	F
<i>LOS Thresholds – Signalized Intersections</i>	
≤ 10	A
> 10 – 20	B
> 20 – 35	C
> 35 – 55	D
> 55 – 80	E
> 80	F

Notes: > - greater than; ≤ - less than or equal to

4. Analysis Volumes

This chapter presents the peak-hour analysis volumes for each scenario, along with the estimated Average Daily Traffic (ADT) volumes; it details the process to forecast the background and total volumes as well as the trip generation and distribution assumptions. The exhibits show the resultant volumes by turning movement at each intersection included in the analyses. This section also describes the derivation of the time period and growth factors used in the forecasting process and the truck percentage input into the microsimulation models.

4.1 Analysis Peak Hour

As collectively determined with CDOT, the analysis peak hour is Saturday from 12:15 to 1:15 pm. This decision was based on the traffic counts collected on Saturday, July 13, 2019, at various intersections along US 40 through the Town of Fraser and Grand County. The six hours of counts at the busiest intersection (US 40 and CR 72) indicate the following peak 60-minute volumes within each time period:

- Total vehicles through intersection:
 - 1,634 vehicles (9–10 a.m.)
 - 2,070 vehicles (12:15–1:15 p.m.)
 - 2,046 vehicles (4–5 p.m.)
- Total bicyclists and pedestrians through intersection:
 - 13 bikes / 29 pedestrians (8:45–9:45 a.m.)
 - 32 bikes / 6 pedestrians (1:00–2:00 p.m.)
 - 17 bikes / 18 pedestrians (4:30–5:30 p.m.)

The peak volume occurred in the noon timeframe, between 12:15 and 1:15 pm. During this vehicular peak hour, 26 bicyclists and 8 pedestrians travelled through the intersection. Review of the southern and northern intersections in the corridor to determine their peak 60-minute volumes suggests the noon timeframe is representative of their peak loading conditions:

- Rendezvous Road: The highest vehicle hours are 1 to 2 p.m. and 4:30 to 5:30 p.m. (the hourly totals only differ by one vehicle for these 2 hours [1,634 to 1,635 vehicles]).
- CR 5: The highest vehicle hour is 4 to 5 p.m., which is only 31 vehicles higher than the 1 to 2 p.m. peak hour (1,342 vehicles)

The peak hour of 1 to 2 p.m. for these two intersections overlaps with the CR 72 intersection peak hour by only 15 minutes. However, the vehicular volume traveling through the CR 72 intersection during the highest-volume 60-minute period is approximately 25 percent higher than CR 5 and Rendezvous Road, and the bicyclists and pedestrians crossings are a higher volume. Therefore, the peak hour of CR 72 intersection governed the selection of the analysis peak hour.

4.2 Annual Growth Rates

The determination of an annual vehicular growth rate was necessary to estimate future years' background vehicle volumes. The vehicular trips generated by the developments are a finite volume that does not grow annually once the development is fully operational; therefore, growth rates are not necessary to estimate future development-related vehicular volumes. Furthermore, the determination of an annual bicycle and pedestrian growth rate was necessary to estimate future years' volumes for these modes which

impact signal timing and cycle length. As there is no standard industry practice for estimating these modal trips as generated by developments, this analysis assumed that application of a growth rate to the 2019 collected volumes will suffice to account for development-generated bicycle and pedestrian volumes.

4.2.1 Vehicles

The annual growth rate to forecast future background vehicular volumes is 1.25 percent per year. This value was based on information gathered from several sources as described in the following list:

- CDOT OTIS Data: The 20-year factor is 1.21 for the segment of US 40 between mile posts 226.835 and 229.621 (these mileposts most closely align with the study corridor mileposts of 226.3 through 228.9). This 20-year factor equates to a 0.96 percent annual growth rate (<http://dtdapps.coloradodot.info/otis/TrafficData#ui/0/1/0/criteria/28305//true/true/>).
- Recent Traffic Impact Studies in the Study Corridor:
 - *Auxiliary Turn Lane Assessment Traffic Impact Study for Riverview Townhomes*, McDowell Engineering, May 28, 2019. This TIS used a CDOT OTIS 20-year factor of 1.24 to calculate an annual growth rate of 1.08 percent. This statement is from the TIS: *Per CDOT, the US Highway 40 corridor is anticipated to have a 1.24 20-year growth factor which equates to a 1.08% annual growth rate in the vicinity of the site* (M3 Property Service 2019, page 10).
 - *Byers Peak Ranch Traffic Impact Study*, May 2019. This TIS used an annual growth rate of 1.0 percent. Future traffic growth estimates from the CDOT OTIS indicate that US 40 is projected to experience approximately 1.0 percent annual growth near the Town of Fraser (Byers Peak Properties 2019, page 11).
 - *Transportation Impact Study for Roam (Formerly Beavers)*, April 15, 2019. This TIS used an annual growth rate of 0.43 percent for US 40. Long-term background growth was based upon the CDOT's published OTIS growth rate calculated for US 40 (Fraser Development Company 2019, page 10).
- *2040 Regional Transportation Plan*, Northwest Transportation Planning Region, February 2015: While the plan does not provide an estimated annual growth rate for traffic volumes on individual routes, it does project VMT will grow 1.7 percent annually (Northwest Transportation Planning Region 2015, page 6). In general, VMT and volume growth rates are similar in most locations, so this annual VMT growth estimate is valid to serve as a comparison to verify the proposed growth rate is reasonable.
- State Demographer's Office: The July 2015 State Demographer's Office estimate of the Grand County population was 14,686, and the forecast for Grand County in 2045 is 23,178. These two values equate to an annual population growth rate of 1.53 percent during this 30-year period. Vehicle trips generally increase as population and employment increases, so this population percent growth estimate is valid to serve as a comparison to verify the proposed growth rate is reasonable (<https://demography.dola.colorado.gov/population/population-totals-counties/#population-totals-for-colorado-counties>).

The growth rate of 1.25 percent per year between now and 2045 is slightly higher than the CDOT OTIS rate or the rates used in recent TISs because it recognizes the higher annual growth rates projected for area population and VMT.

4.2.2 Bicycles and Pedestrians

The annual growth rate to forecast future bicycle and pedestrian volumes of 1.5 percent per year was based on the following two values:

- The State Demographer's Office population forecasts, which suggest an annual population growth rate of 1.53 percent in Grand County.
- The recommended vehicular volume annual growth rate of 1.25 percent for the study corridor.

Bicycle and pedestrian volumes are likely to increase during the study period for various reasons. Bicycle growth is anticipated in the future as Fraser and Winter Park continue to emphasize and provide facilities for bicyclists to commute and recreate. Furthermore, the Givelo Trail from the west currently makes connection to the Fraser to Winter Park Trail in the vicinity of the CR 72 intersection. A higher volume of bicycle and pedestrian traffic is anticipated along these two regional trail systems in future, and a portion of this additional bicycle and pedestrian volume will likely use the CR 72 intersection to cross US 40 and travel between the shopping and residential destinations on the east and north side of the highway. Furthermore, enhanced transit service and desires to improve parking and circulation will likely increase pedestrian activity in Fraser and across US 40. Per the Northwest Transportation Planning Region Regional Plan and meeting minutes from the Economic Development Advisory Council meeting on September 24, 2019, there are current and future plans for regional transit services such as Bustang and Greyhound to access Fraser.

The current pedestrians and bicyclists in the area are composed of residents and visitors, but information to distinguish these two within the counts is not available. For the proportion of this volume that is comprised of residents, an annual growth rate equal to the estimated population annual growth rate is reasonable. Although a similar growth estimate is not available for visitors, annual vehicle volume growth rates comprise all traffic and, therefore, include residents and visitors. The annual vehicular growth rate would be a reasonable surrogate for the bicycle and pedestrian annual growth rate.

4.3 Heavy Vehicle Percentage

The percentage of heavy vehicles (trucks and recreational vehicles) within the traffic stream is an input into the Vissim models. Determination of this value was based on information gathered from the sources described in the following list:

- CDOT OTIS Data: The projected heavy vehicle percentage is 4.9 percent for the segment of US 40 that encompasses the study corridor between mile posts 226.835 and 229.621, (these mile posts most closely align with the study corridor mile posts of 226.20 through 228.40) (<http://dtdapps.coloradodot.info/otis/TrafficData#ui/0/1/0/criteria/28305//true/true/>).
- Recent Traffic Counts in the Study Corridor:
 - Hourly classification counts were collected on US 40 at two locations in the study corridor on July 13, 2019: just north of the fire station access and just north of CR 5. Assuming the truck percentage will include Classes 4 through 13, the following percentages were recorded at these two locations:
 - West of Fire Station: 602 buses/trucks or 3.2 percent of the daily total of 18,767.
 - West of CR 5: 1,207 buses/trucks or 8.3 percent of the daily total of 14,556.
 - There is a large difference between the two truck percentages, suggesting that the larger vehicles are not all travelling the full length of the study corridor through Fraser. The primary difference is

in Class 5, with the proportion of two-axle, 6-tire vehicles almost 2.5 times greater west of CR 5 than at the east end of the corridor. This difference may be attributable to trips destined for the shopping areas adjacent to County Roads 72 and 804 from origins west of Fraser.

- Historic Traffic Counts on CR 5: Grand County provided historical hourly classification counts from one location on CR 5 in July 2013 and May 2014. These counts suggest the heavy vehicle percentage based on truck trips associated with a gravel mining operation ranges from 6 to 9 percent for a few hours during the middle of the weekday. This peak time frame for the gravel pit operations does not coincide with the study area peak hour of noon on Saturdays.

Representing a smoothed percentage over a few miles, the CDOT OTIS percentage falls within the middle of the two values obtained from traffic counts. Therefore, the CDOT value of 4.9 percent seems to be a reasonable approximation of the study corridor heavy vehicle percentage and was used in the Year 2019 Existing Conditions and Year 2022 Existing Plus Committed Interim Conditions models.

The heavy vehicle percentage input into the Vissim models to represent the effect of heavy vehicles in the future traffic stream was increased to 5.4 percent to account for the expected opening of the Granby RV park after 2022. Recreational vehicles (RV) are included in the truck classifications (cars and pickups pulling campers are not included in the truck classifications). Once the RV park is operational in Granby, the volume of RVs and cars pulling campers traveling through Fraser on US 40 is likely to increase. Assuming these vehicles would be new to the traffic stream, the additional RVs will likely cause an increase in the proportion of heavy vehicles. Therefore, it would be prudent to increase the CDOT OTIS truck percentage slightly to account for the impact of RVs on traffic operations. The analysis estimated these additional vehicles would create a 0.5 percent increase in the heavy vehicle percentage, acknowledging that most vehicles traveling to the Granby RV park will be cars or pickups pulling campers rather than the larger, single-unit RVs. Therefore, the heavy vehicle percentage was increased to 5.4 percent in the 2045 No Build and Build models.

4.4 Year 2019 Existing Conditions Volumes

This condition reflects the year 2019 existing peak hour volumes with refinements to balance between intersections. To provide a complete assessment of the study area traffic operations, the microsimulation analysis files include all the minor intersections between Rendezvous Road and CR 5. Since these minor intersections were not all included in the data collection and post-processing effort, turning movement volumes for them were determined through a hand-assignment process that effectively balanced the volumes between intersections. The bicycle and pedestrian volumes were not post-processed and reflect the raw counts collected for this study during the 12:15 to 1:15 p.m. timeframe. **Exhibit 6** shows the turning movement volumes used for the midday analysis at each of the study area intersections.

4.5 Year 2022 Existing Plus Committed Conditions Scenario Volumes

This scenario reflects the year 2022 vehicular peak hour volumes, which are the sum of the forecasted background and development-generated volumes. The background volumes were determined by applying the 1.25 percent annual vehicle growth factor and the 1.5 percent annual bicycle/pedestrian growth factor to the 2019 volumes for three years through 2022 (and rounding up to the nearest five value). Similar to the Year 2019 Existing Conditions, the CR 72 intersection has the highest cross-street volume in the study area. As reflected in the turning movement volumes for this intersection, the demand volume is higher to the east of this intersection. **Exhibit 7** shows these volumes by turning movement at each study area intersection.

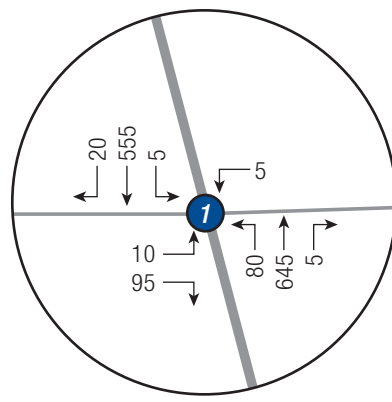
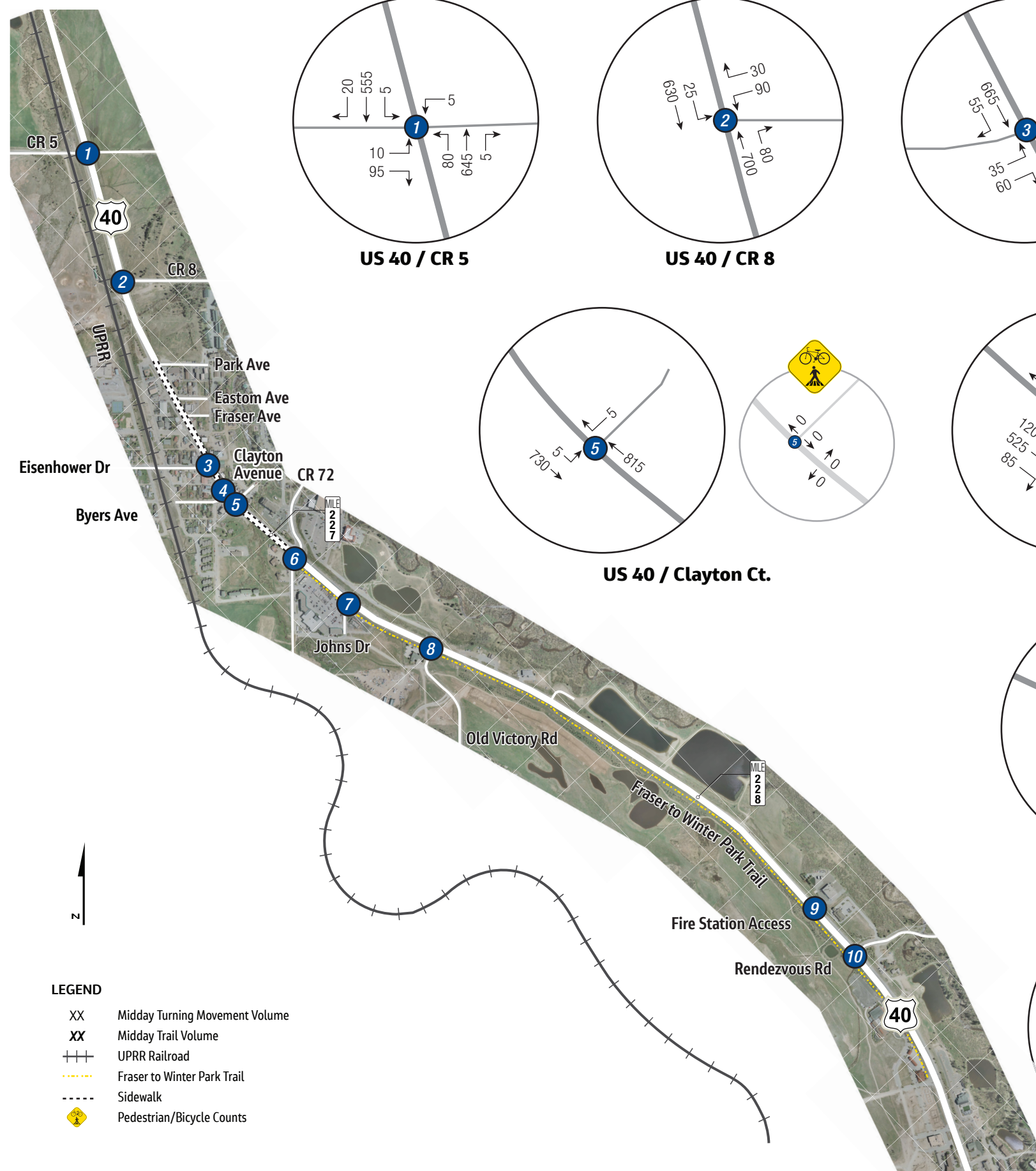

US 40 / CR 5

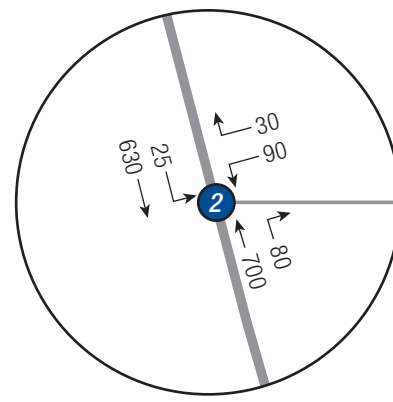

US 40 / CR 8

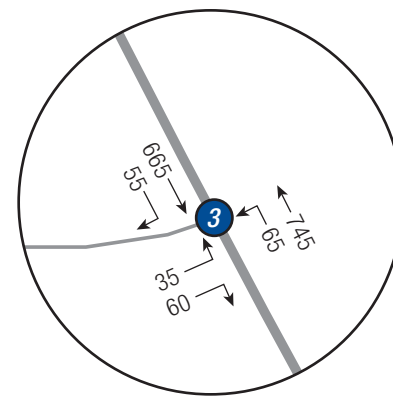

US 40 / Eisenhower Dr.

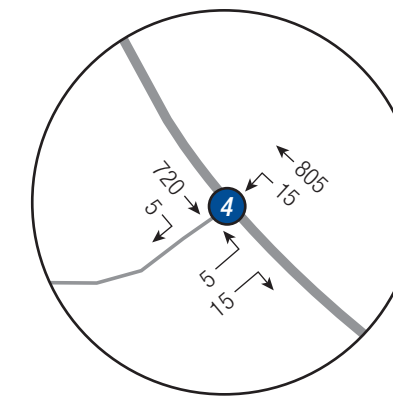
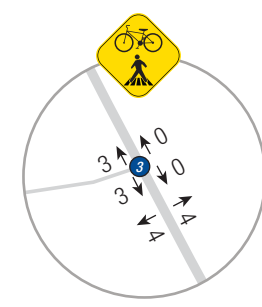

US 40 / Byers Ave.

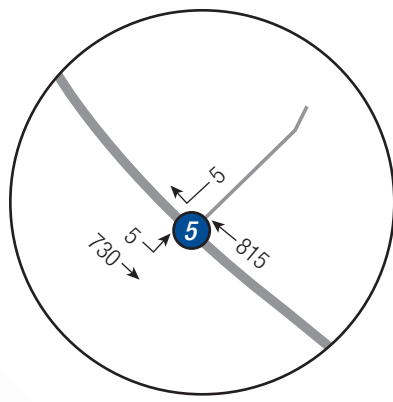
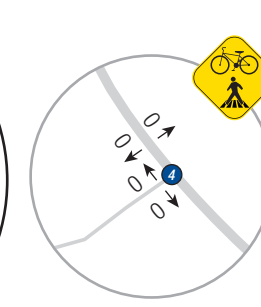

US 40 / Clayton Ct.

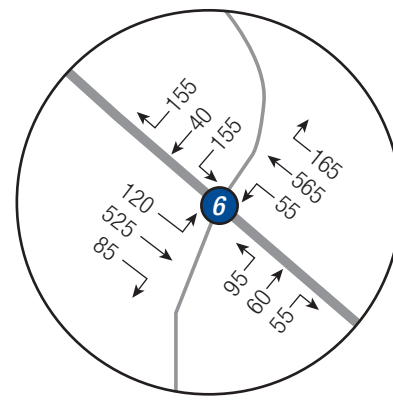
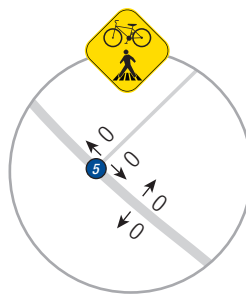

US 40 / CR 72

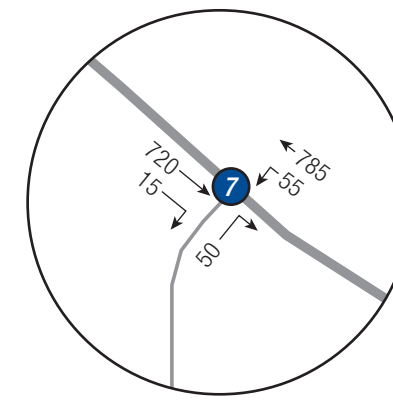
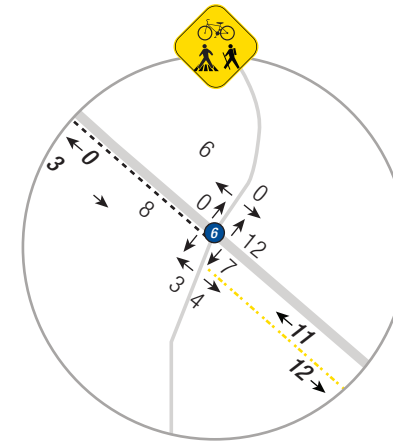

US 40 / Johns Dr.

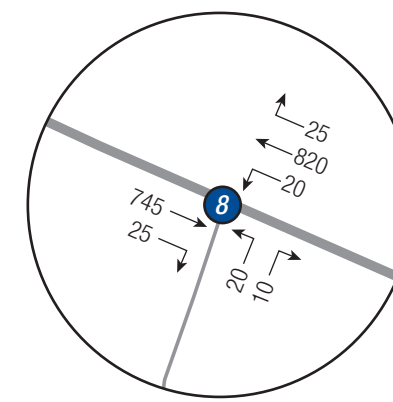

US 40 / Old Victory Rd.

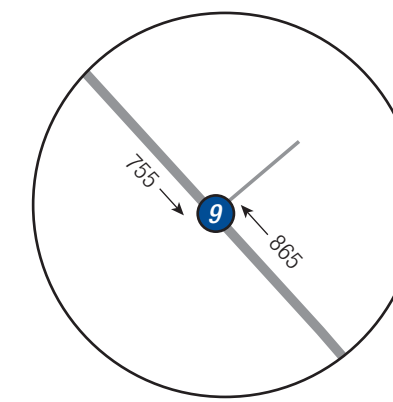
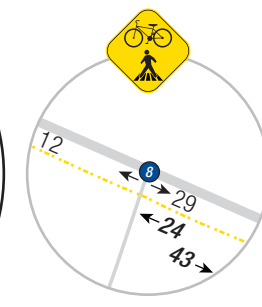

US 40 / Fire Station

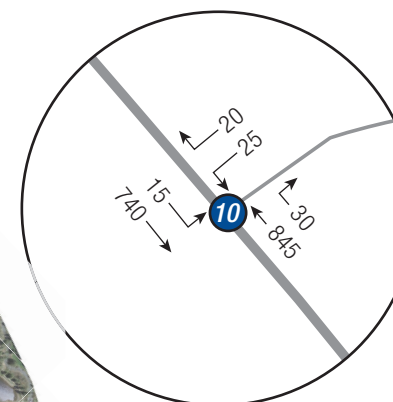

US 40 / Rendezvous Rd.

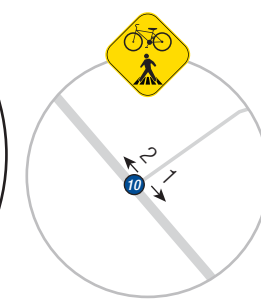

- LEGEND**
- XX Midday Turning Movement Volume
 - XX Midday Trail Volume
 - ++ UPRR Railroad
 - Fraser to Winter Park Trail
 - Sidewalk
 - ⚠ Pedestrian/Bicycle Counts

Exhibit 6. 2019 Existing Peak Hour Traffic & Trail Volumes
CDOT Region 3
US 40 – Fraser

Exhibit 7 also shows the projected ADT at the east and west study area limits. Primarily as a result of the proposed development, the ADT is projected to increase between 62 (east end) and 65 percent (west end) compared to the 2019 counts. Development-generated trips account for approximately 94 percent of this volume increase and 36 percent of the total projected ADT at both ends of the study corridor in year 2022. **Exhibit 8** depicts the composition of the projected daily volumes in year 2022 at each end of the study corridor.

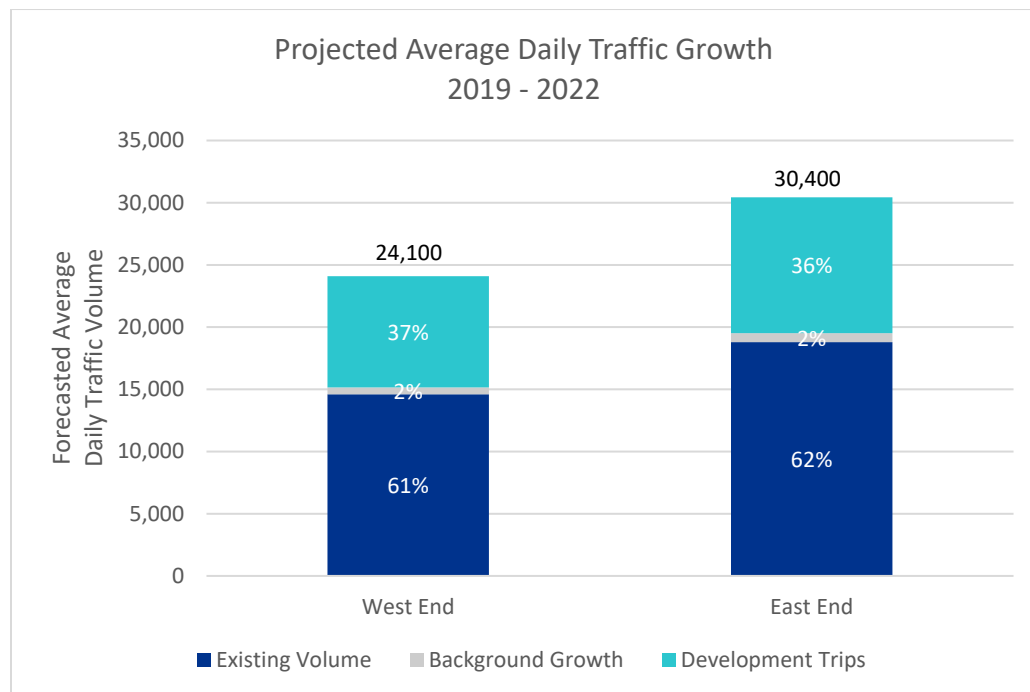
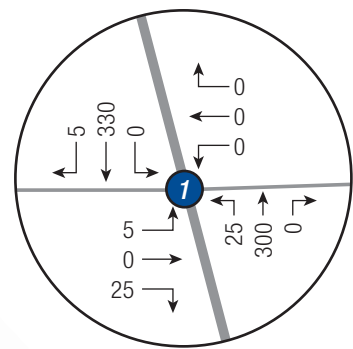
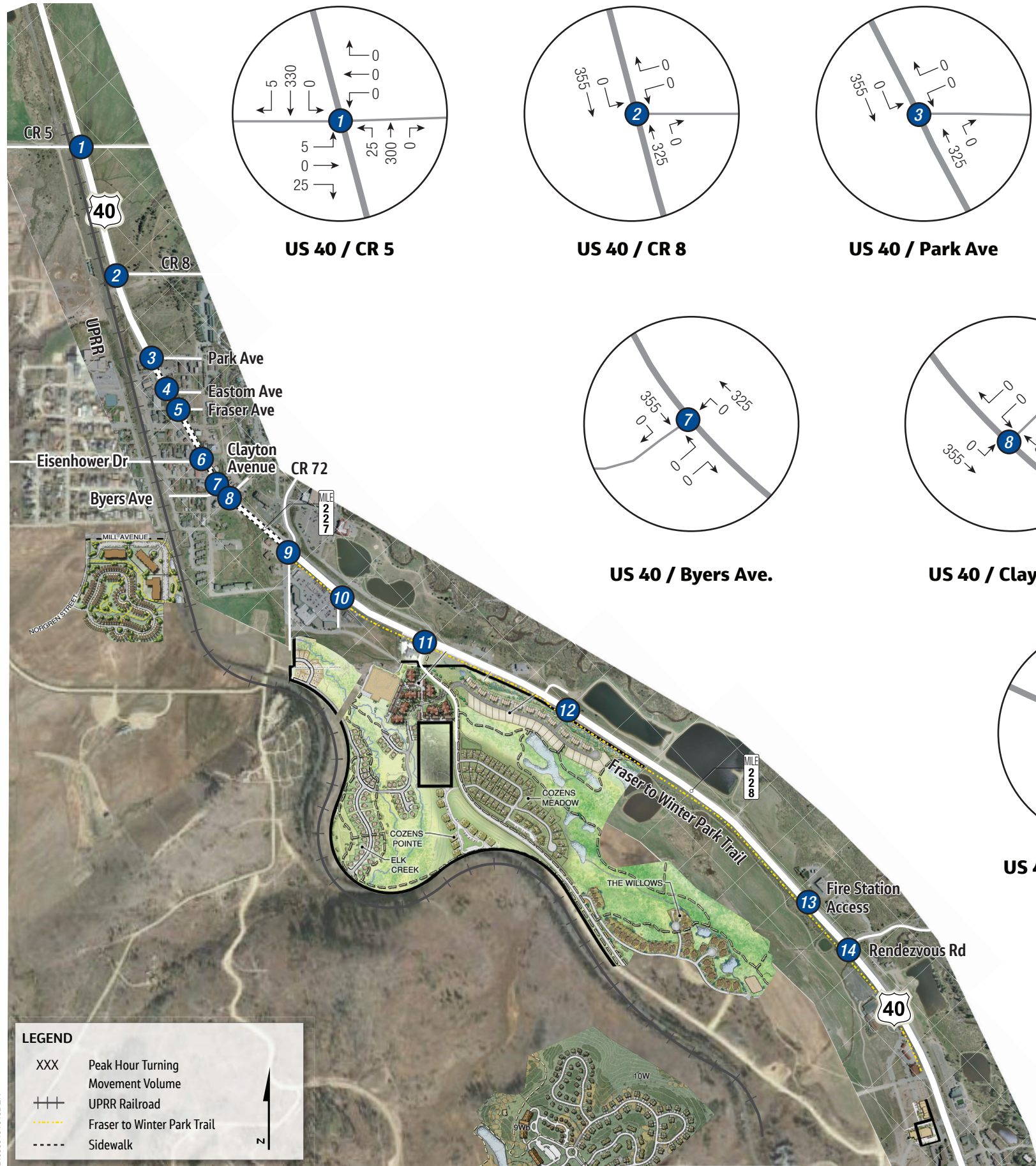

Exhibit 8. Year 2022 Average Daily Traffic Composition

Exhibit 9 shows the volume and distribution of the development-generated trips through the study area. These trips reflect the development anticipated to be completed by or within the year 2022. The access locations to US 40 are concentrated at the CR 5, Eisenhower Drive, CR 72, Old Victory Road, Meadows RIRO, and Rendezvous Road intersections. These intersections represent the closest locations from the various developments and are reflective of the limited options in the local area roadway network to cross US 40 and travel north/south through the study area. CR 72 is the intersection with the highest trip-generated volume.

Table 2 summarizes the trip generation and distribution assumptions for the Year 2022 Existing Plus Committed Interim Conditions scenario that support the volumes shown in **Exhibit 9**. Note that the individual values per development do not sum to the volumes shown on **Exhibit 9** at the access point intersections, because the turning movement volumes are rounded up to the nearest five vehicles in the exhibit and the analysis files. Altogether, an estimated 1,265 peak hour trips are expected to be generated from new developments to be complete by or within year 2022.



US 40 / CR 5

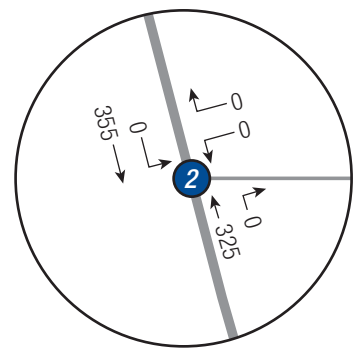

US 40 / CR 8

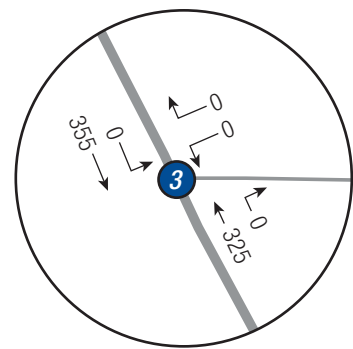

US 40 / Park Ave

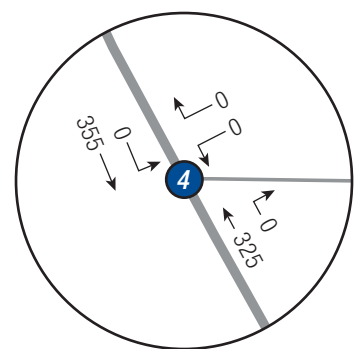

US 40 / Eastom Ave

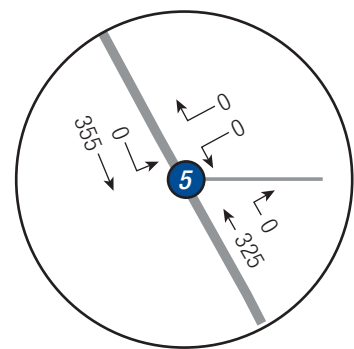

US 40 / Fraser Ave

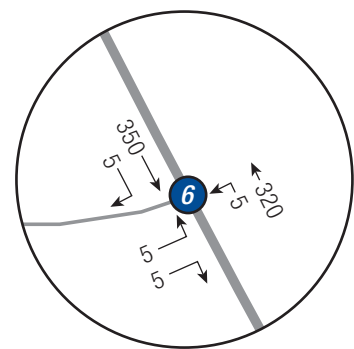

US 40 / Eisenhower Dr.

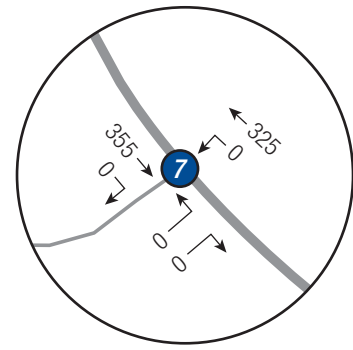

US 40 / Byers Ave.

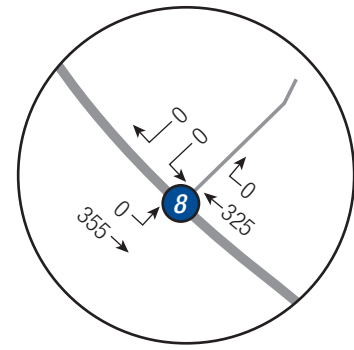

US 40 / Clayton Ct.

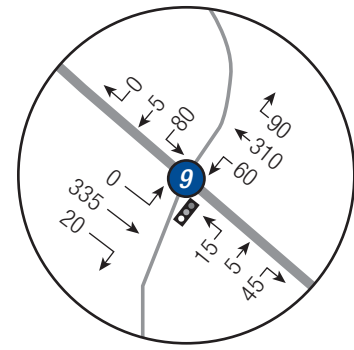

US 40 / CR 72

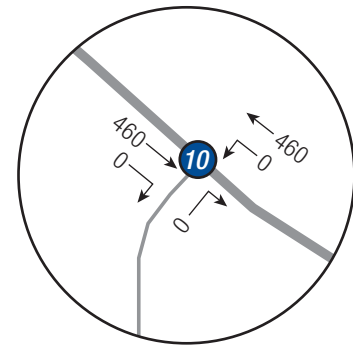

US 40 / Johns Dr.

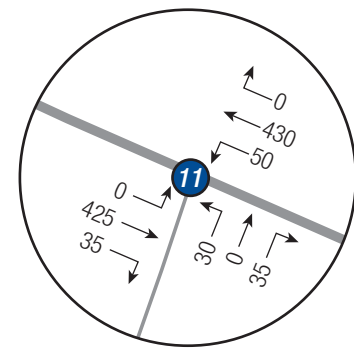

US 40 / Old Victory Rd.

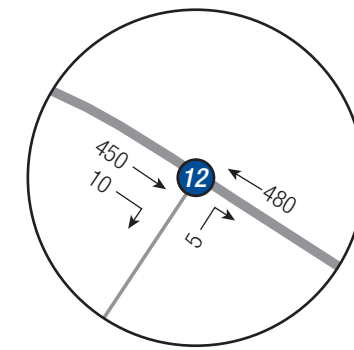

US 40 / Meadows RIRO

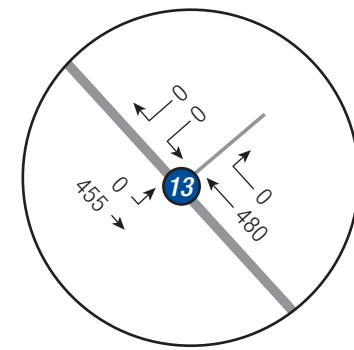

US 40 / Fire Station

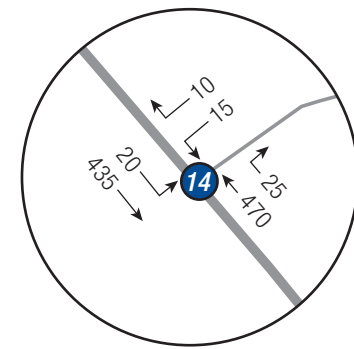

US 40 / Rendezvous Rd.

Exhibit 9. 2022 Peak Hour Trip Generation Estimates
 CDOT Region 3
 US 40 – Fraser

B:\0606191013\DEN

Table 2. Year 2022 Existing Plus Committed Interim Scenario Trip Generation and Distribution Assumptions

Development	Land Use	PM Peak Hour Trip Generation	Assumptions	US 40 Access Points	Assumptions
Byers Peak Ranch	123 single family (detached)	123	Data supplied by Clark Lipscomb	30% to/from west at Eisenhower, CR 72, and Old Victory intersections	FHU TIS Figure 6 (assume future distribution applies to interim condition).
	60 apartments (mid-rise)	25	Data supplied by Clark Lipscomb	40% to/from east at Eisenhower, CR 72, and Old Victory intersections	Of the 70% accessing US 40, 10% will use Eisenhower, 45% use CR 72, and 45% use Old Victory intersections.
			Referenced PM Peak Hour of Generator in ITE Manual rather than PM Peak Hour of Adjacent Street Traffic because analysis uses mid-day volumes	5% of total trips use CR 72 intersection to cross US 40	At each intersection, 40% to/from west and 60% to/from east.
	Total	148			
Grand Park	30,000 SF medical center	140	Data supplied by Clark Lipscomb	Kings Crossing and 2nd Street	45% to/from US 40 study area to represent development distribution to/from west. 2nd Street is RIRO only. Distribution based on FHU TIS 2013, Figure 8.
	110 hotel rooms	68	Data supplied by Clark Lipscomb	1st and 2nd Streets (west leg of Rendezvous Road will not be open in 2022)	45% to/from US 40 study area to represent development distribution to/from west. 2nd Street is RIRO only. Distribution based on FHU TIS 2013, Figure 8.
	41,000 SF retail (shopping center)	173	Data supplied by Clark Lipscomb	1st and 2nd Streets	45% to/from US 40 study area to represent development distribution to/from west. 2nd Street is RIRO only. Distribution based on FHU TIS 2013, Figure 8.
	134 single family (detached)	134	Data supplied by Clark Lipscomb	1st Street (using new railroad grade separation)	45% to/from US 40 study area to represent development distribution to/from west. Distribution based on FHU TIS 2013, Figure 8.
	14 single family (detached)	14	Data supplied by Clark Lipscomb	CR 72	45% to/from west of US 40 study area & 55% to/from east of US 40 study area. Distribution based on July 2019 daily counts.
	84 condos (mid-rise)	35	Data supplied by Clark Lipscomb	Old Victory Road	45% to/from west of US 40 study area & 55% to/from east of US 40 study area. Distribution based on July 2019 daily counts.
	Total	564	Referenced PM Peak Hour of Generator in ITE Manual rather than PM Peak Hour of Adjacent Street Traffic because analysis uses mid-day volumes		
Grand Park Meadows PA 3WC	21 single family (detached)	21	Data supplied by Clark Lipscomb	15 trips in peak hour will use the new Right-in/Right-out intersection with US 40, per Access Permit	Peak hour vehicle volume from Access Permit.
	44 townhomes (low-rise)	30	Data supplied by Clark Lipscomb	Remainder of trips will use Old Victory intersection	45% to/from west of US 40 study area & 55% to/from east of US 40 study area. Distribution based on July 2019 daily counts.
	Total	51	Referenced PM Peak Hour of Generator in ITE Manual rather than PM Peak Hour of Adjacent Street Traffic because analysis uses mid-day volumes		
Rendezvous	60 single family (detached)	60	Entitlement Agreement	Rendezvous Road, then 40% west and 60% east of the US 40 study area	Distribution based on FHU TIS 2004 , page 12.
	Total	1,082			
Winter Park Arrows	multi-family, commercial		Data from Arrows TIS	Rendezvous Road, CR 72, CR 5 intersections	26 northbound trips and 28 southbound trips through US 40 study area per Arrows TIS.
					50% of these trips originate/destined for CR 72. North/south split at CR 72 based on data collected in July 2019.
	Total	54			
Winter Park Sitzmark	multi-family, supermarket		Data from Sitzmark TIS	Rendezvous Road, CR 72, CR 5 intersections	96 northbound trips and 127 southbound trips through US 40 study area per Sitzmark TIS.
	commercial				50% of these trips originate/destined for CR 72. North/south split at CR 72 based on data collected in July 2019.
	Total	223			
Winter Park Roam Phase 1	single family, multi-family		Data from Roam TIS	Rendezvous Road, CR 72, CR 5 intersections	125 northbound trips and 52 southbound trips through US 40 study area per Roam TIS.
	office, retail, park, restaurant				50% of these trips originate/destined for CR 72. North/south split at CR 72 based on data collected in July 2019.
	Total	177			

Table 2. Year 2022 Existing Plus Committed Interim Scenario Trip Generation and Distribution Assumptions

Development	Land Use	PM Peak Hour Trip Generation	Assumptions	US 40 Access Points	Assumptions
Transit Center	Transit operations center	48	Saturday midday peak hour volume from TIS, Figure 8. Per TIS Page 13, 75% of trips will occur by 2020.	At CR 5, 90% to the east and 5% to the west of US 40 study area.	TIS page 15. All of the trips to/from west will be occurring by 2020.
		1,265	Total PM Peak Hour Development-Generated Trips		

The table entries show the derivation of the volumes and the intersections at which the trips enter the study area. The magnitude and routing of the trips are based on information from approved traffic impact studies and access permits along with data provided by area developers (refer to Chapter 2, Data Collection, for more information). The analysis peak hour for this study area is a Saturday around noon, which is not a typical peak hour that is analyzed for TISs. Evening peak hour volumes and rates from these sources were used for this trip generation effort for two reasons: the evening peak hour typically represents a higher volume, and therefore worse-case scenario, for the commercial land uses and the evening peak hour typically represents a more even entry and exit ratio for residential land uses, which is assumed to be more reflective of a weekend noon hour than a morning peak hour entry and exit distribution.

For the data sourced from developers for Byers Peak Ranch, Grand Park, and Rendezvous, the generated trips and entry/exit ratios were estimated by applying the ITE TripGen land-use specific rates to the number of dwelling units/hotel rooms or square footage of commercial/retail/ medical uses provided by the developers. To apply the ITE rates, the Weekday PM Peak Hour of Generator time period was used instead of the Weekday PM Peak Hour of Adjacent Street traffic because the analysis peak hour occurs around noon. Internal capture for the Grand Park development was not included in the Year 2022 forecast because the specific types of commercial land uses were not available. Without necessary information to determine appropriate internal capture values, the decision was made to not account for a potential reduction in trips. Thus, the analysis is more conservative with a forecast that does not include what could be a slight reduction in trips due to internal capture between the residences and commercial uses within the Grand Park development.

TISs have been developed and approved for the Byers Peak Ranch, Grand Park, and Rendezvous developments (the Rendezvous TIS was completed when the name of the development on the south side of US 40 was Rendezvous; it was subsequently changed to Grand Park). However, the implementation is not necessarily occurring at the same pace as anticipated during the conduct of these studies. Although the actual development to be complete in year 2022 was determined from data provided by the developers and not the TIS documentation, the east/west distribution proportions along US 40 are assumed to be applicable to this trip generation effort. For Byers Peak Ranch, the trip distribution to the access intersections was obtained from the traffic impact study documentation. For Grand Park and Rendezvous, the access intersections were chosen by this analysis effort based on the shortest travel distance between the development and US 40. Based on the roadway network, most of the Grand Park trips generated in 2022 that are traveling to destinations west of Fraser are projected to access US 40 at the First Street or Kings Crossing intersections. Since these intersections are east of the study area, these Grand Park trips are routed along the study area as through movements on US 40.

The Grand Park distribution of 45 percent to the west and 55 percent to the east on US 40 matches the proportions of daily volume collected at each end of the corridor for this analysis. Although a slightly different distribution of 40 percent west/60 percent east was proposed in study documentation for the Byers Peak Ranch and Rendezvous developments, in general, the higher demand and resultant trip generation volume is toward Winter Park.

The peak hour volume generated by the Grand Park Meadows development was distributed between the Old Victory Road intersection and the new the RIRO access to eastbound US 40. The total trips generated in the evening peak hour were estimated using the ITE rate and then 15 of these were distributed to the RIRO intersection per information obtained from the access permit. The entry/exit distribution through these two intersections was based on the west/east ratio of the daily volume data collected in July 2019 for this study.

Evening peak hour volumes were obtained from the Arrows, Sitzmark, and Roam TIS documentation. The Arrows, Sitzmark, and Roam developments are in Winter Park. The documentation of these traffic impact studies provided general distributions north of Winter Park but did not specifically discuss the origins or destinations within Fraser. Therefore, half of these trips are assumed to access Fraser through the CR 72 intersection. This cross street provides access to a lot of current residential development within the Town of Fraser and the Byers Peak Ranch development that will be in place by 2022 and seems a reasonable location for these trips to access the highway. The north/south split at CR 72 duplicates this ratio for existing volume data at this intersection. The other half of the trips destined for locations west of Fraser are routed as through movements at every study area intersection.

A CDOT maintenance facility is planned to be located adjacent to CR 5 and south of US 40. As this development is in the early planning stages and information is not available for use in trip generation, this analysis assumed two trucks would enter and two would exit the facility through the CR 5 intersection with US 40 during the peak hour. The Transit Center development is under the purview of the Town of Winter Park. Saturday mid-day peak hour volumes and distributions were obtained from the traffic impact study documentation. The documentation noted that 75 percent of the development would be complete in 2020. As **Table 2** shows, this analysis assumes that all the trips to and from the west would begin with this initial development phase. The remainder of the trips are assumed to travel through the US 40 intersection with CR 5 and travel the length of the study corridor as through movements at the other study area intersections to access Winter Park.

4.6 Year 2045 No Build and Build Scenarios

This scenario reflects the year 2045 vehicular peak hour volumes, which are the sum of the forecasted background and development-generated volumes. The year 2045 forecast is the same for the no build and build (signal, roundabout, and refined signal alternatives) scenarios. This assumption was necessary because the Applied Factor Method used to forecast the future volumes is not a dynamic process; as a result, the process does not account for varying travel patterns based on driver preferences such as delay tolerances and type of intersection control.

Exhibit 10 shows these volumes by turning movement at each of the study area intersections. The background volumes were determined by applying the 1.25 percent annual vehicle growth factor and the 1.5 percent annual bicycle/pedestrian growth factor to the 2019 volumes for the years 2019 through 2045 (and rounding up to the nearest five value). Like the year 2022, the demand volume is higher to the east of the CR 72 intersection. The development-generated volumes within these total volumes represent all the anticipated development in the study area between 2019 and 2045 and apply to all the year 2045 scenarios because the trip generation does not change between the future no build and build scenarios (the differences between the scenarios are related to geometric configuration).

After completion of the demand forecasting and operational analysis modelling, information became available about an increase in densities for the Byers Peak Ranch land uses over what was included in the May 2019 traffic impact study referenced to develop the forecast volumes. The additional trips generated by the higher densities are accounted for in the Fraser Valley Parkway analysis that is documented in the technical memorandum in **Appendix G**.

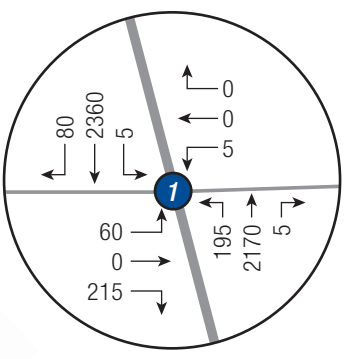
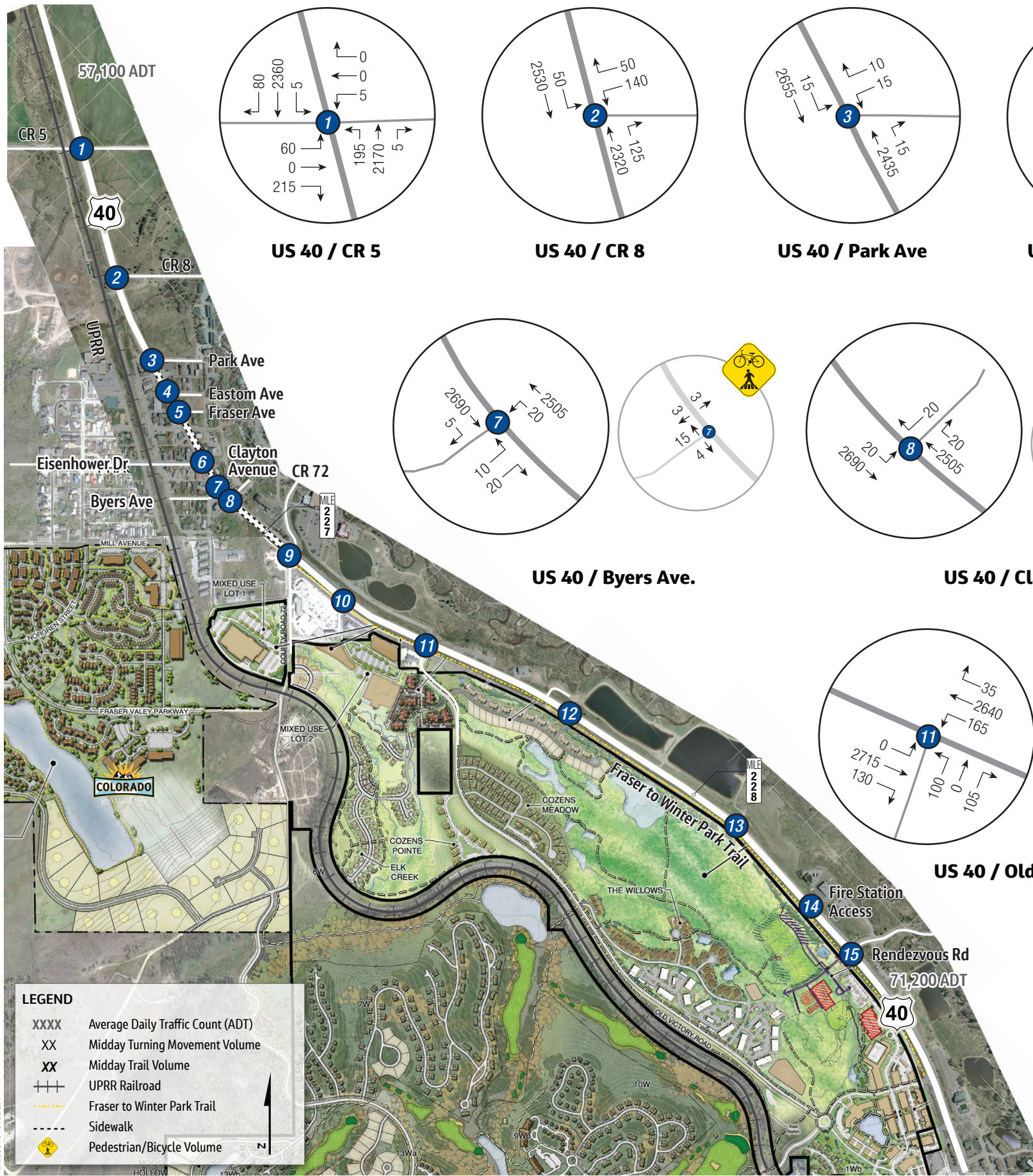

US 40 / CR 5

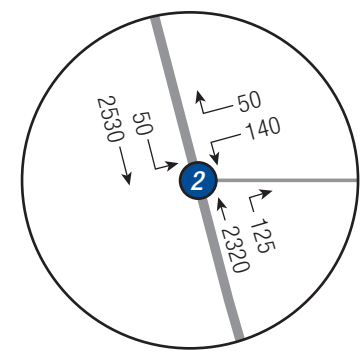

US 40 / CR 8

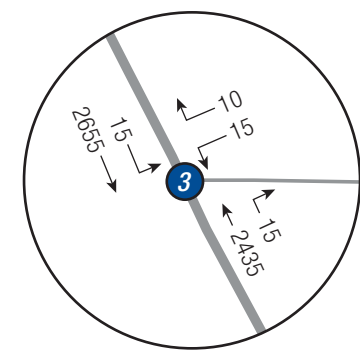

US 40 / Park Ave

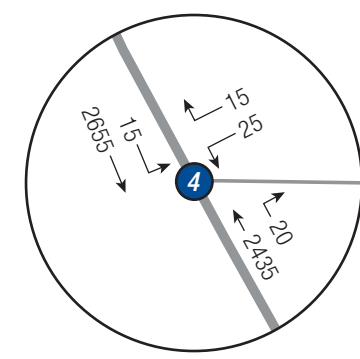

US 40 / Eastom Ave

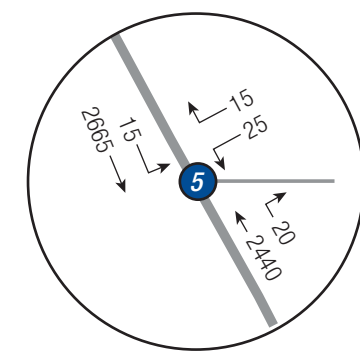

US 40 / Fraser Ave

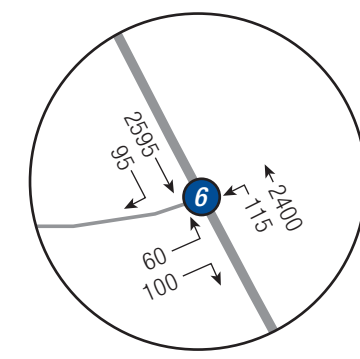

US 40 / Eisenhower Dr.

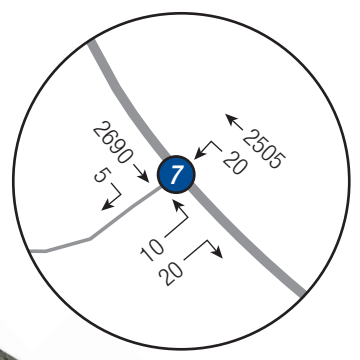
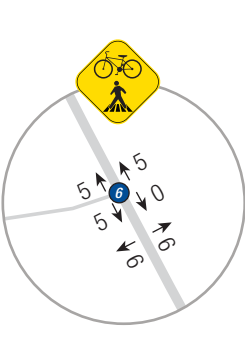

US 40 / Byers Ave.

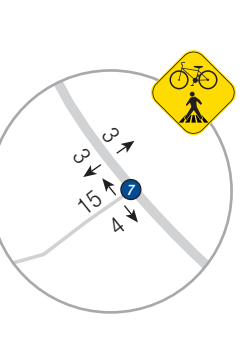

US 40 / Clayton Ct.

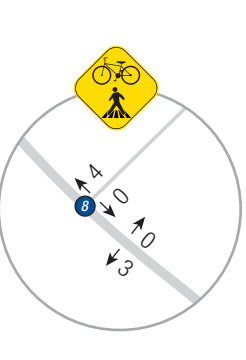
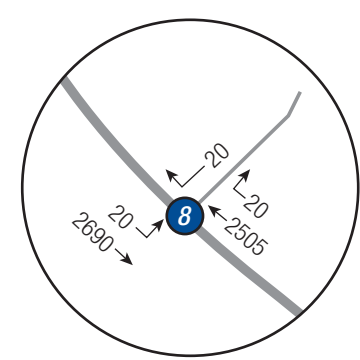

US 40 / Old Victory Rd.

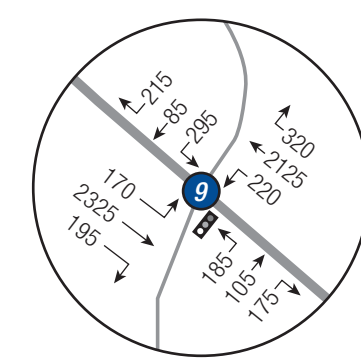

US 40 / Meadows RIRO

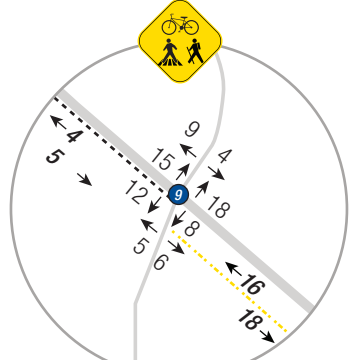

US 40 / CR 72

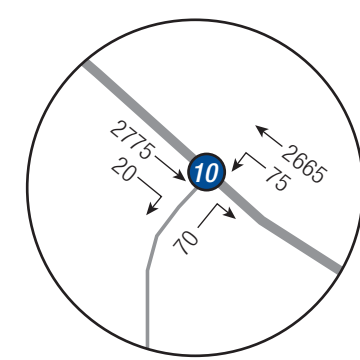

US 40 / Fire Station

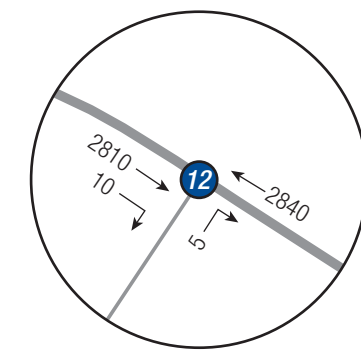
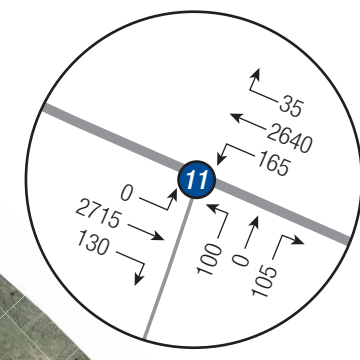

US 40 / Old Victory Rd.

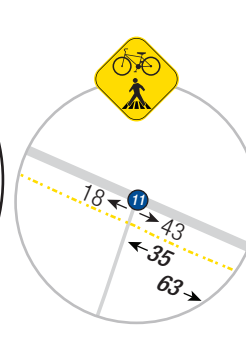

US 40 / Meadows RIRO

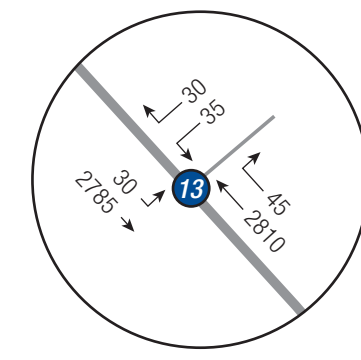

US 40 / 14E PA Access

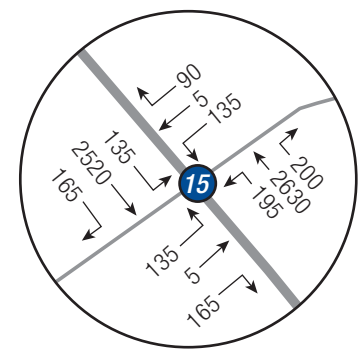
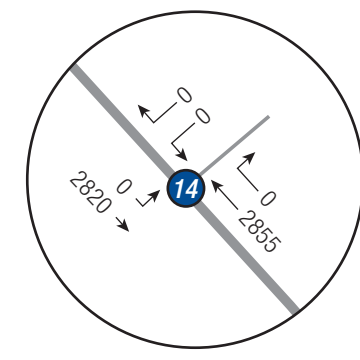

US 40 / Rendezvous Rd.

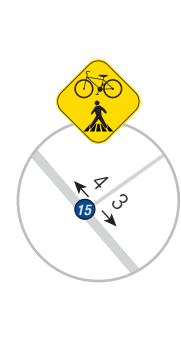

LEGEND

- XXXX Average Daily Traffic Count (ADT)
- XX Midday Turning Movement Volume
- XX Midday Trail Volume
- +++ UPRR Railroad
- Fraser to Winter Park Trail
- Sidewalk
- Icon Pedestrian/Bicycle Volume

Exhibit 10. 2045 Peak Hour Traffic & Trail Forecasts Without Fraser Valley Parkway
 CDOT Region 3
 US 40 – Fraser

Exhibit 10 also shows the projected ADT at the east and west study area limits. Primarily as a result of the proposed development, the ADT is projected to nearly quadruple compared to the 2019 counts. Development-generated trips account for approximately 85 percent of this volume increase and nearly two-thirds of the total projected ADT at both ends of the study corridor in year 2045. **Exhibit 11** depicts the composition of the projected daily volumes in 2045 at each end of the study corridor.

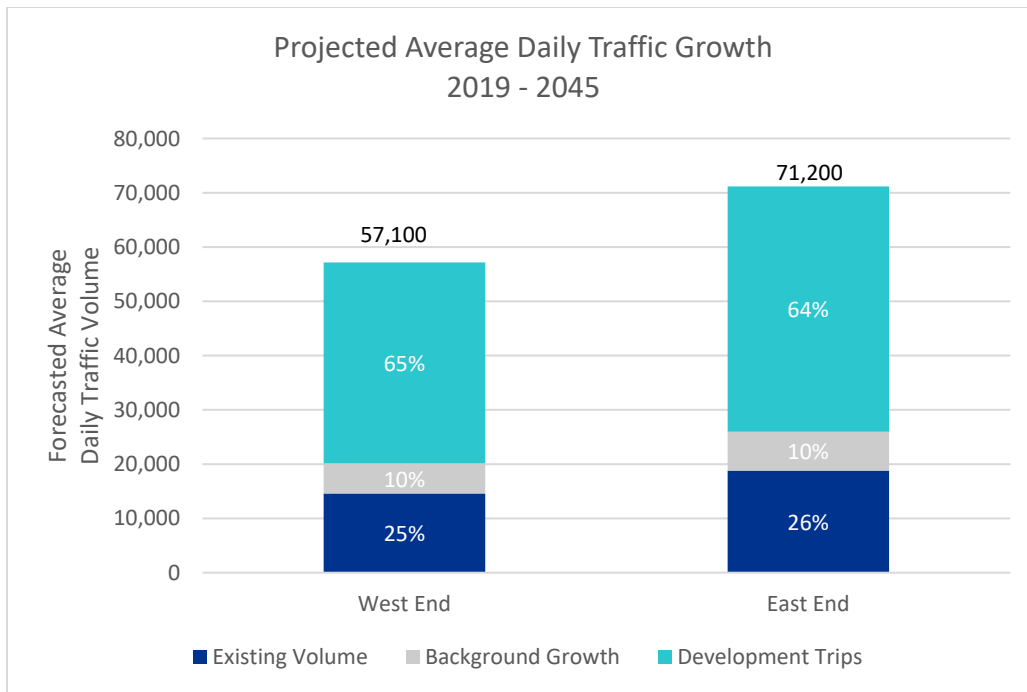

Exhibit 11. Year 2045 Average Daily Traffic Composition

Exhibit 12 shows the volume and distribution of the development-generated trips through the study area for developments anticipated to be completed between years 2023 and 2045. These volumes and the trip generation volumes shown in **Exhibit 9** for the Year 2022 Existing Plus Committed Interim Conditions scenario volumes together represent the total expected trip generation within the study area between years 2019 and 2045. Reflecting future development adjacent to the west limit of the study corridor, more US 40 intersections serve as access points to the highway. Near the east limit of the corridor, a new full-movement intersection is added west of the Fire Station Access to serve the Rendezvous development on the north side of US 40. Rendezvous Road has an additional approach on the south side of US 40 and is the intersection with the highest trip-generated volume for developments to be implemented between 2023 and 2045. The only study area intersections that do not serve development-generated trips by year 2045 are Byers Avenue, Johns Drive, and the Fire Station Access. **Exhibit 13** shows these additions to the roadway network along with the existing primary access locations to US 40 as red lines.

Table 3 summarizes the trip generation and distribution assumptions for the 2045 scenarios that support the volumes shown in **Exhibit 12**. The developments assumed to be completed by year 2023, such as the CDOT maintenance facility and the Winter Park developments, are not included in this table. Note that the individual values per development do not add up to the volumes shown on **Exhibit 12** at the access point intersections because the turning movement volumes are rounded up to the nearest five vehicles in the exhibit and the analysis files. Altogether, an estimated 5,380 peak hour trips will be generated from new developments to be complete between and including the years 2023 and 2045.

4.6.1 Lift Operations Center Development

As **Table 3** shows, the completion of the Lift Operations Center development would add 15 trips to the analysis peak hour in year 2045. All these trips would travel the length of the study corridor to access Winter Park.

4.6.2 Downtown Fraser Developments

The Poleyard, Victoria Village, and Riverwalk District developments are proposed in the *2017 Downtown Fraser Strategic Plan* (Strategic Plan). While this visionary plan proposes types of land uses and access locations, it does not specify numbers of dwelling units, square footages for commercial establishments, or trip distribution. Therefore, assumptions were made for these values based on land area, input from Town of Fraser personnel, illustrations in the Strategic Plan, and probable intersection configurations based on the draft alternatives formulated as of the time this analysis was completed. The access location to US 40 for the Poleyard was assumed to be the CR 5 intersection because it is the only existing at-grade railroad crossing that is accessible from the existing roadway network. Only two of the three access locations shown in the Strategic Plan for Victoria Village were used for trip distribution because this analysis assumes the addition of a new access point to US 40 at this location will not be permissible (depicted with the red circle in **Exhibit 14**, which is excerpted from the Strategic Plan). The trips were therefore distributed evenly between the other two access points to US 40 (shown with the blue circles in **Exhibit 14**), at Park Avenue and CR 8. Likewise, trips were evenly distributed between the Riverwalk District access points to US 40 at Clayton Avenue, Fraser Avenue, and Eastom Avenue (shown with the blue circles in **Exhibit 14**). Consistent with the daily count data collected in July, the distribution on US 40 for these three developments is assumed to be 45 percent to the west and 55 percent to the east. Finally, the mixed-use land uses assumed for the Poleyard and Riverwalk District were suggested by Town of Fraser personnel. Warehousing type space for workshops with retail space is assumed for part of the Poleyard development and main floor retail with upper level residential is assumed for a portion of the Riverwalk District. Internal capture was accounted for within the Riverwalk District based on the vision for walk-in access to the restaurant and market land uses.

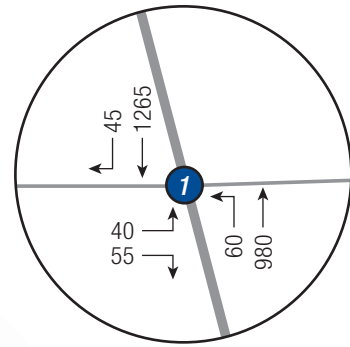
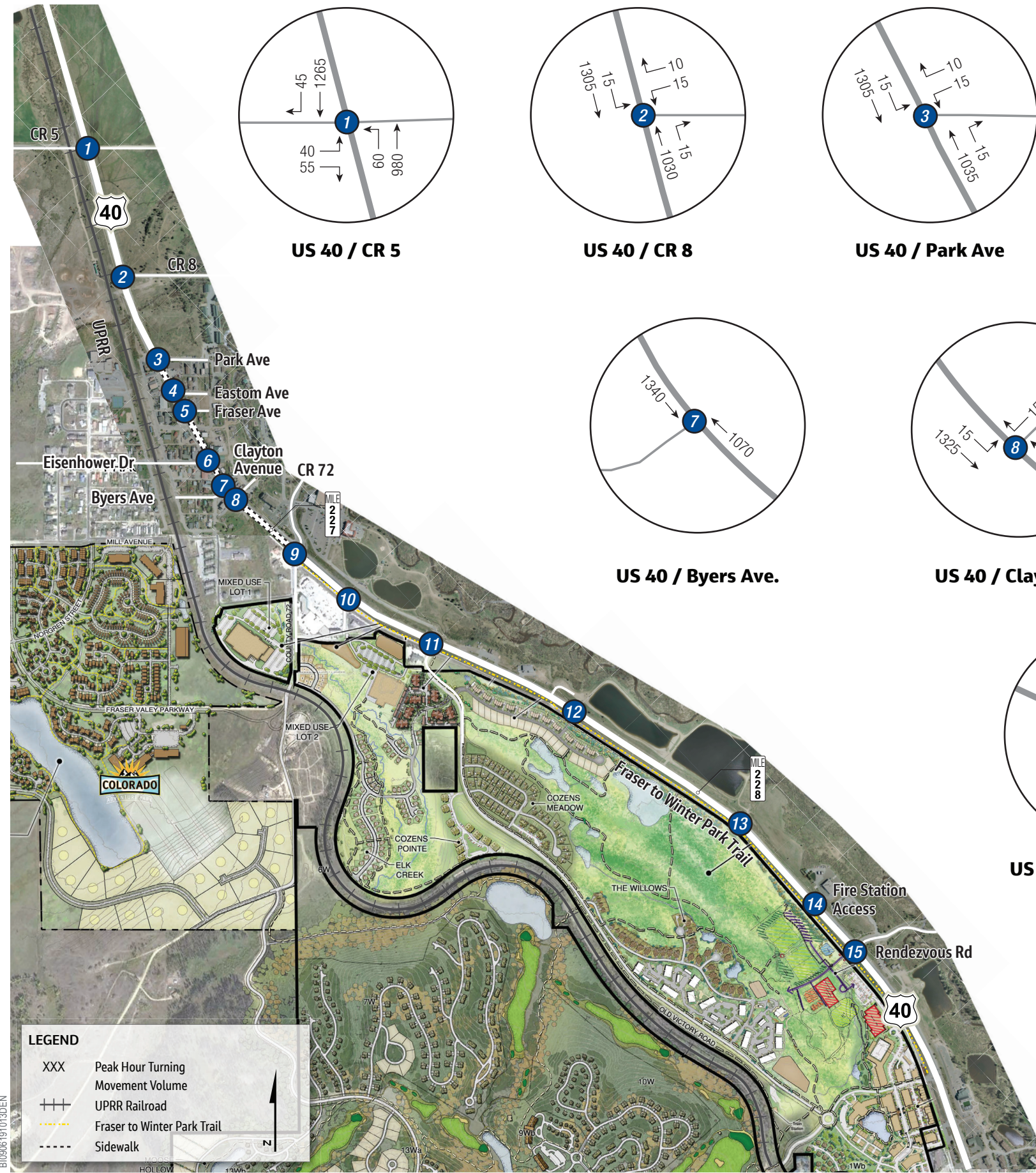

US 40 / CR 5

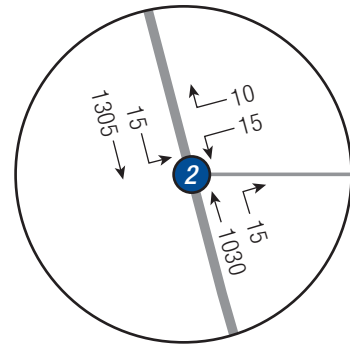

US 40 / CR 8

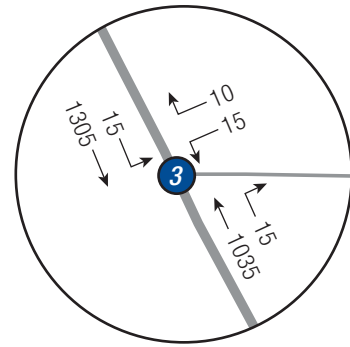

US 40 / Park Ave

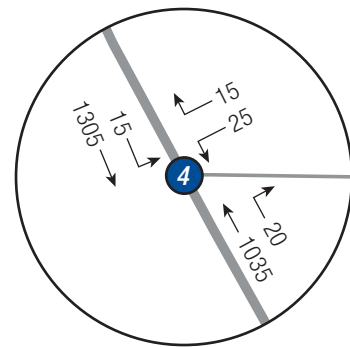

US 40 / Eastom Ave

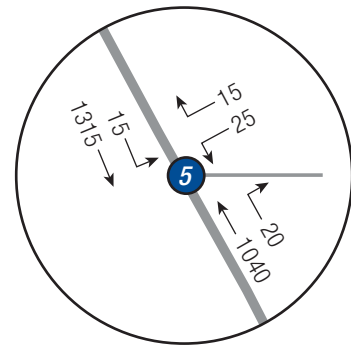

US 40 / Fraser Ave

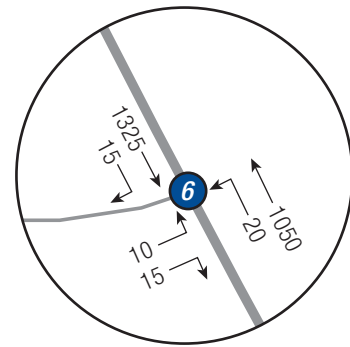

US 40 / Eisenhower Dr.

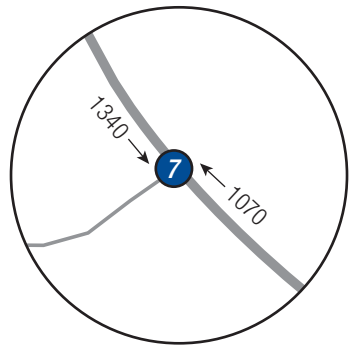

US 40 / Byers Ave.

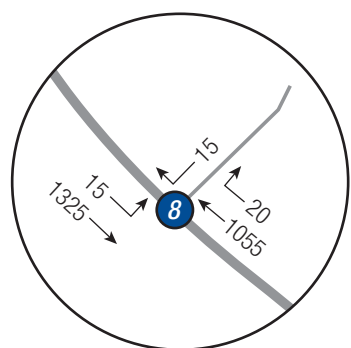

US 40 / Clayton Ct.

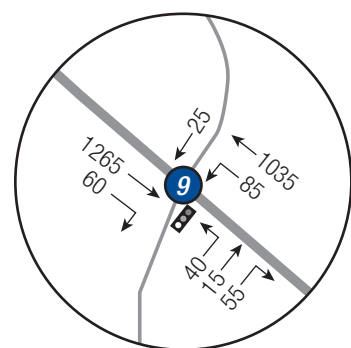

US 40 / CR 72

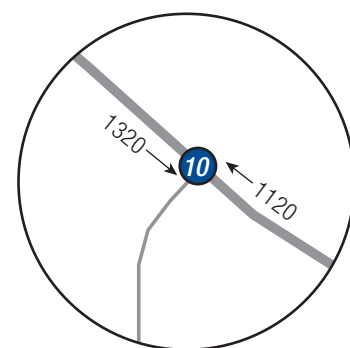

US 40 / Johns Dr.

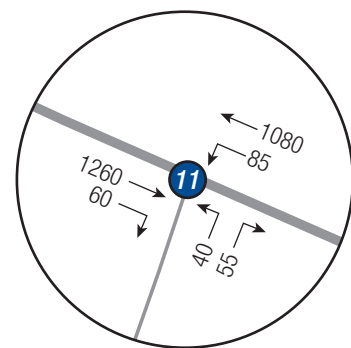

US 40 / Old Victory Rd.

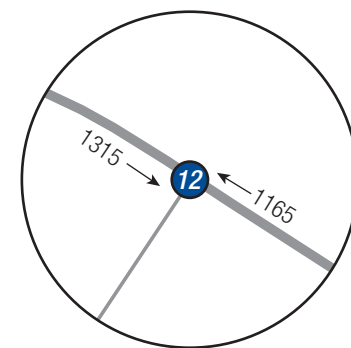

US 40 / Meadows RIRO

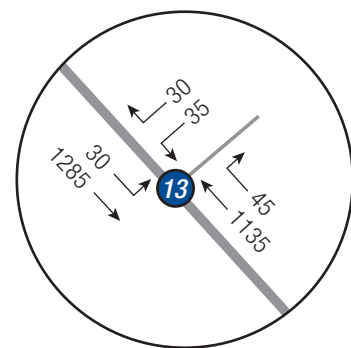

US 40 / 14E PA Access

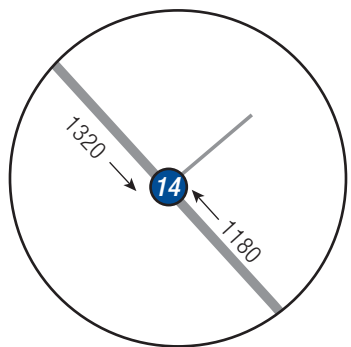

US 40 / Fire Station

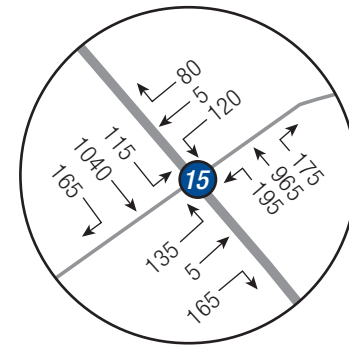

US 40 / Rendezvous Rd.

Exhibit 12. 2023 Through 2045 Peak Hour Trip Generation Estimates
 CDOT Region 3
 US 40 – Fraser

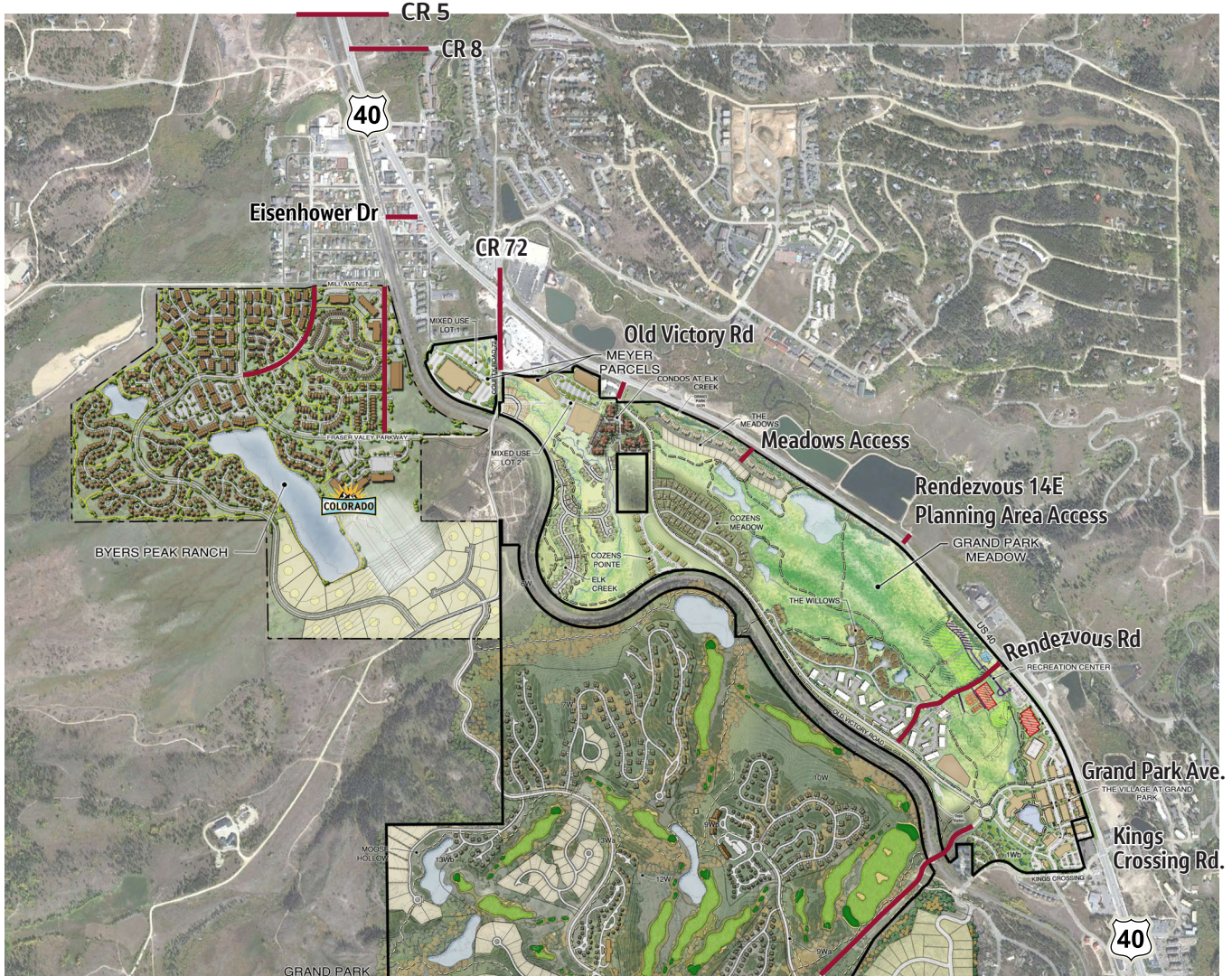

LEGEND

— Proposed Roadway

Exhibit 13. 2045 Build Condition Proposed Roadway Network
 CDOT Region 3
 US 40 – Fraser

Exhibit 13. Year 2045 Build Condition Proposed Roadway Network

Table 3. Year 2045 Trip Generation and Distribution Assumptions

Development	Land Use	PM Peak Hour Trip Generation	Assumptions	US 40 Access Points	Assumptions
Maintenance Facility	CDOT Maintenance Facility	4	2 trucks entering and 2 trucks exiting during peak hour. Employees will not be commuting during this midday peak hour.	At CR 5, 50% to the east and 50% to the west of US 40 study area.	
Transit Center	Transit operations center	15	Saturday midday peak hour volume from TIS, Figure 8. Per TIS Page 13, 25% of trips will occur by 2040.	At CR 5, 90% to the east and 5% to the west of US 40 study area.	TIS page 15.
Poleyard	15 multi-family (low-rise) units per acre	51	10 acres as measured on Google Earth. Measured area matches exhibit in Downtown Strategic Plan page 7. Town of Fraser directed 15 units per acre for multi-family. Half of acreage is residential.	At CR 5, 45% to/from west of US 40 study area & 55% to/from east of US 40 study area.	Distribution based on July 2019 daily counts.
	4,000 SF (supermarket)	31	20,000 SF total of non-residential land uses.		
	4,000 SF (restaurant)	70	Use General Light Industrial to replicate land use in which artisans work and sell product in same space. Modified ITE information to 50% enter/50% exit in peak hour.		
	4,000 SF (retail)	17	Referenced PM Peak Hour of Generator in ITE Manual rather than PM Peak Hour of Adjacent Street Traffic because analysis uses mid-day volumes.		
	8,000 SF (light industrial)	7			
	Total		176		
Victoria Village	52 multi-family (low-rise)	35	Counted units shown on page 15 in Downtown Strategic Plan.	At Park Avenue and CR 8, 45% to/from west of US 40 study area & 55% to/from east of US 40 study area.	Distribution based on July 2019 daily counts.
	2,500 SF (supermarket)	15	5,000 SF total of non-residential land uses. Square footage estimate based on exhibit shown on page 15 in Downtown Strategic Plan and text describing neighborhood-supported retail.	Access locations shown on page 15 of Downtown Strategic Plan, Assume middle access point to US 40 shown in exhibit will not be allowed by CDOT.	Trip reduction to account for neighborhood-supported market and dining.
	1,200 SF (coffee shop)	27	Referenced PM Peak Hour of Generator in ITE Manual rather than PM Peak Hour of Adjacent Street Traffic because analysis uses mid-day volumes.	Volumes split evenly between Park Avenue and CR 8.	
	1,200 SF (restaurant)	17	Assume 25% reduction in generated trips for eateries / supermarket because of neighborhood walk-in traffic.		
	Total		94		
Riverwalk District	Multi-family (low-rise)	47	9 acres as measured on Google Earth. Measured area matches exhibit in Downtown Strategic Plan page 7.	At Clayton, Fraser, and Eastom Avenues, 45% to/from west of US 40 study area & 55% to/from east of US 40 study area.	Distribution based on July 2019 daily counts.
	Condos with first floor retail	30	Assume 4.6 acres is multi-family (low-rise) residential. Town of Fraser directed 15 units per acre for multi-family.	Access locations shown on page 14 of Downtown Strategic Plan. Assume middle access points to US 40 shown in exhibit will not be allowed by CDOT.	Trip reduction to account for neighborhood and riverwalk-supported retail and dining.
	2,500 SF (coffee shop)	53	Assume 5000 SF split between coffee shop and restaurant.	Access split evenly between Clayton, Fraser, and Eastom Avenues, with the exception of restricted left-out at Clayton Avenue.	
	2,500 SF (restaurant)	33	Assume 4.4 acres is ground floor retail with upper floors condos.		
				Assume 25% reduction in generated trips for restaurant / coffee shop because of neighborhood walk-in traffic.	
	Total		163	Referenced PM Peak Hour of Generator in ITE Manual rather than PM Peak Hour of Adjacent Street Traffic because analysis uses mid-day volumes.	
Byers Peak Ranch	296 single family (detached)	296	Subtract the 123 single family in interim condition from the total number in TIS Table 2.	30% to/from west at Eisenhower, CR 72, and Old Victory intersections	TIS Figure 6
	65 multi-family (mid-rise)	27	Subtract the 60 apartments in interim condition from the total number in TIS Table 2.	40% to/from east at Eisenhower, CR 72, and Old Victory intersections	Of the 70% accessing US 40, 10% will use Eisenhower, 45% use CR 72, and 45% use Old Victory intersections.

Table 3. Year 2045 Trip Generation and Distribution Assumptions

Development	Land Use	PM Peak Hour Trip Generation	Assumptions	US 40 Access Points	Assumptions
	356 multi-family (low-rise)	239	Total number in TIS Table 2.	5% of total trips use CR 72 intersection to cross US 40.	At each intersection, 40% to/from west and 60% to/from east.
	125 hotel rooms	77	Total number in TIS Table 2.		
	20,000 SF commercial (shopping center)	85	Total SF value in TIS Table 2.		
	Total	724	Referenced PM Peak Hour of Generator in ITE Manual rather than PM Peak Hour of Adjacent Street Traffic because analysis uses mid-day volumes.		
Grand Park	686 single family (detached)	686	Using Grand Park Annexation Agreement Entitlement Density Chart, subtract out these Planning Areas based on Clark Lipscomb's pdf indicating what is built or currently under construction: 1WA 41ksf commercial/bowling alley/theatre (Cornerstone) & 1W3(Meadows) & Housing portion of 2W & 3WA/B/C & 4W & 5W & 16 of the 9W houses & 10W.	15% of the 96% of generated trips that will access US 40 will use new Rendezvous Road intersection west leg. Then, 45% of these trips will be to/from west.	Distribution based on FHU TIS 2013, Figure 9.
	652 multi-family (low-rise)	437		85% of the 96% of generated trips that will access US 40 will use 1st Street/2nd Street/Kings Crossing. Then, 45% of these trips will be to/from west in US 40 study area.	Distribution based on FHU TIS 2013, Figure 9.
	653 multi-family (mid-rise)	268			
	1168 hotel rooms	713			
	354,800 SF commercial (shopping center)	1494			
	Total	3,598		Referenced PM Peak Hour of Generator in ITE Manual rather than PM Peak Hour of Adjacent Street Traffic because analysis uses mid-day volumes.	
Rec Center Expansion					
Rendezvous	111 single family (detached)	111	Used aerial imagery to identify which filings/planning areas have been developed.	Rendezvous Road, then 40% west and 60% east of the US 40 study area.	Distribution based on FHU TIS 2004 , page 12.
	205 multi-family (low-rise)	137	Counted homes shown in aerial imagery to determine number of homes developed for Filing 1 and part of background traffic.	Proposed unsignalized full movement intersection with US 40, west of fire station access, then 40% west and 60% east of the US 40 study area, for PA 14E only.	Per TIS, trips reduced to reflect internal capture: 12E (6%),13E (3%), and 14E(4%).
	205 multi-family (mid-rise)	84	Split multifamily in half - 50% is low-rise and 50% is mid-rise.		
	130 hotel rooms	77	Assume Filing 2 is complete and part of background traffic.		
	49,200 SF commercial (shopping center)	197	Referenced PM Peak Hour of Generator in ITE Manual rather than PM Peak Hour of Adjacent Street Traffic because analysis uses mid-day volumes.		
	Total	606			
		5,380	Total PM Peak Hour Development-Generated Trips		



LEGEND

- Proposed Access Point
- Access Point Not Used in Trip Distribution

Exhibit 14. Proposed Access Points from Victoria Village and Riverwalk District Developments to US 40
CDOT Region 3
US 40 – Fraser

4.6.3 Byers Peak Ranch Development

All of the commercial land uses and 80 percent of the housing units in Byers Peak Ranch would be developed after year 2022. The number of houses and apartment units used in the trip generation estimation was derived by subtracting the number constructed prior to year 2022 (refer to **Table 2**) from the total values provided in the TIS. The hotel and retail land uses, along with the mid-rise multi-family use, were assumed to all be constructed after year 2022 to the magnitude shown in the traffic impact study. Internal capture was not included because the specific types of commercial land uses were not available. Without necessary information to determine appropriate internal capture values, the decision was made to not account for a potential reduction in trips. Thus, the analysis is more conservative with a forecast that does not include what could be a slight reduction in trips due to internal capture between the residences and commercial uses within Byers Peak Ranch. For consistency with the TIS, the same distributions to the roadway network for the Existing Plus Committed Interim Conditions scenario were assumed for the future scenarios.

4.6.4 Grand Park Development

The Grand Park development would also primarily be developed after year 2022 with the addition of approximately 77 percent of the housing land uses and 90 percent of the commercial and lodging land uses. The values used in the trip generation estimations were derived by subtracting the development prior to/within the year 2022 from the total values listed in the Annexation Agreement Entitlement Density Chart. Local developers provided information about the types and sizes of land uses to be completed prior/to within the year 2022. Internal capture was not included because the specific types of commercial land uses were not available.

The distribution of the trips to US 40 varies from the year 2022 because a south approach is added to the Rendezvous Road intersection. Following the traffic impact study, 15 percent of the trips were routed through this Rendezvous Road intersection while the remainder were routed through intersections east of the study area, accessing Grand Park Drive and Kings Crossing Drive. Like the year 2022 condition, the distribution on US 40 remains the same at 45 percent to the west and 55 percent to the east. The Cornerstone recreation center expansion is also part of the Grand Park development. The peak hour trip generation was based on information provided by local developers as to probable land use types and sizes. The Rendezvous Road access to US 40 was also assumed because of its proximity to these fields and courts

4.6.5 Rendezvous Development

The access points for the Rendezvous development are the existing Rendezvous Road signalized intersection and a proposed unsignalized intersection to the west that would serve one planning area that is solely residential land use. The values used in the trip generation estimations were derived by subtracting the development prior to or within the year 2022 from the total values listed in the Annexation Agreement Entitlement Density Chart. The units completed prior to or within the year 2022 were estimated by counting rooftops on aerial imagery and assuming that the development associated with Filing 2 is complete per aerial imagery. The internal capture reduction was applied per the traffic impact study, as well as the 40 percent west/60 percent east distribution on US 40.

5. Operations Analysis Results

This section presents the results of the operations analyses conducted following the methodology presented in Chapter 3. The section includes the estimated operating conditions and travel times for the Saturday midday peak hour (12:15 to 1:15 p.m.) for the existing condition, and the projected operating conditions and travel times for the existing plus committed interim condition and no build and build scenarios. The future scenarios and volumes reflect the roadway network without a Fraser Valley Parkway facility. **Tables 4 through 10** present delay and level of service results for the signalized intersections overall and for the worst movement for the unsignalized intersections. Following the results discussions, **Table 11** summarizes these values by movement for each intersection in every condition and scenario. **Appendix E** contains the operations analysis output reports that include projected queue lengths.

5.1 Year 2019 Existing Conditions

As **Table 4** shows, the existing intersection conditions within the US 40 corridor limits operate at acceptable LOS overall and for each movement during the Saturday midday peak hour with the 2019 volume conditions. The Vissim model estimated travel time for the study limits is 3.5 minutes in the westbound direction with an average speed of 39 miles per hour (mph). In the eastbound direction, the corridor travel time is 3.3 minutes with an average speed of 41 mph. Because the average speed and travel time estimates include intersection-related delay at the CR 72 and Rendezvous Road intersections, these speed values suggest drivers generally can travel close to the posted speed limits. Both time estimates are similar to the travel time data collection results.

Table 4. Year 2019 Existing Scenario Level of Service Results

Intersection	2019 Existing		
	Traffic Control	Delay (sec/veh)	LOS
US 40/CR 5	TWSC	10	B
US 40/CR 8	TWSC	14	B
US 40/Eisenhower Drive	TWSC	14	B
US 40/Byers Avenue	TWSC	16	C
US 40/Clayton Avenue	TWSC	10	A
US 40/CR 72	Signal	19	B
US 40/Johns Drive	TWSC	4	A
US 40/Old Victory Road	TWSC	21	C
US 40/Fire Station Access	TWSC	9	A
US 40/Rendezvous Road	Signal	4	A

Note:

Bold text indicates a primary intersection.

sec/veh – seconds(s) per vehicle

TWSC - two-way stop control

An average delay of 19 seconds per vehicle is encountered at the CR 72 signalized intersection, which provides an overall service level of LOS B. This level of delay results because the higher-volume through movements on US 40 experience relatively low delays of 15 seconds (westbound) and 18 seconds (eastbound). However, the movements on CR 72 experience more delay with average through movement delays of 49 seconds (northbound) and 44 seconds (southbound) per vehicle in the peak hour. The left-turn delays of 34 and 36 seconds result in queue lengths of 65 feet (northbound left) and 120 feet (southbound left), which are contained within the existing left-turn lanes. The model estimates that the US 40 through-movement queue lengths average 40 feet during the peak hour. These results may not match anecdotal evidence of longer through movement queues on US 40 at this intersection during peak demand days, which could be attributed to a lower volume condition within the study limits during the particular July Saturday on which data was collected. The Vissim model is calibrated per industry standards to the volume and travel time data collected in the study corridor. At the east end of the corridor, the eastbound and southbound left-turn movements experience the highest delays through the Rendezvous Road intersection at 42 and 41 seconds per vehicle, respectively. These delays provide LOS D operations in the peak hour. Overall, this intersection currently provides LOS A operating conditions in the peak hour.

At the two-way stop-controlled intersections (designated as TWSC in the results tables), delay is encountered primarily for left-turn movements to and from the intersecting streets. The highest amount of average delay for vehicles turning to or from US 40 is 21 seconds, at the unsignalized intersection with Old Victory Road. Because the nearest signal to this cross street for the westbound travel direction is more than a mile upstream at Rendezvous Road, a metering effect does not occur and fewer gaps are provided for left-turning traffic from Old Victory Road to westbound US 40. The least amount of delay is at the John's Drive intersection; this lower amount of delay is likely due to the platooning effect of the upstream signal at CR 72, which provides gaps for the left-turn movements. The left-turn movements from CR 5 and CR 8 experience average delays of 10 and 14 seconds, respectively.

5.2 Year 2022 Existing Plus Committed Interim Condition

This condition uses volumes that incorporate forecasted background traffic growth and trips generated by approved development expected to be complete before or during year 2022. The only change to the existing study area roadway network is the addition of a RIRO-only intersection east of Old Victory Road for access to the Meadows at Grand Park development adjacent to eastbound US 40, which is under construction as of the writing of this traffic report. The forecasts do not account for a Fraser Valley Parkway facility.

Table 5 shows the LOS and overall average delay per vehicle whereas **Table 11** shows the average delay for individual movements. The yellow highlights for the overall LOS letter designation indicate it is at the lower limit of acceptable or just into the unacceptable range. Red highlights indicate unacceptable, failing operations. As the table indicates, LOS decreases at each intersection when compared to existing conditions due to the additional traffic expected to use US 40 through the study corridor in year 2022. This decrease in operational efficiency is attributable primarily to the volume increase caused by development-generated traffic and not the background volume growth over the 3-year period from 2019 to 2022. As discussed in Section 4.5, development-generated trips account for approximately 94 percent of the projected daily volume increase.

Table 5. Year 2022 Existing Plus Committed Interim Condition Level of Service Results

Intersection	2022 Existing + Committed		
	Traffic Control	Delay (sec/veh)	LOS
US 40/CR 5	TWSC	34	D
US 40/CR 8	TWSC	129	F
US 40/Eisenhower Drive	TWSC	483	F
US 40/Byers Avenue	TWSC	97	F
US 40/Clayton Avenue	TWSC	11	B
US 40/CR 72	Signal	36	D
US 40/Johns Drive	TWSC	38	E
US 40/Old Victory Road	TWSC	342	F
US 40/Meadows	TWSC	16	C
US 40/Fire Station Access	TWSC	38	E
US 40/Rendezvous Road	Signal	24	C

Note:

Bold text indicates a primary intersection.

The additional delay that results in a lower LOS for the signalized intersections is evident with travel time estimates that are double (7.0 minutes westbound and 5.9 minutes eastbound) those for the existing condition. These increased travel times correlate with the lower average travel speeds of 19 mph (westbound) and 22 mph (eastbound). In the eastbound direction, the projected travel time of 1.8 minutes (44 mph average speed) for the segment between CR 72 and Rendezvous Road is similar to the year 2019 existing condition. This result occurs because the additional delay encountered at the CR 72 intersection is serving to meter the traffic volume downstream. Therefore, the increased travel time in the eastbound direction is encountered west (upstream) of the CR 72 intersection. A similar result occurs for the westbound direction in that the increase in travel time is experienced upstream of the CR 72 intersection between Rendezvous Road and CR 72, rather than downstream due to the metering effect of the delay and reduced throughput at this intersection.

The CR 72 intersection is projected to operate at LOS D overall in the peak hour in 2022 with an average delay that nearly doubles compared to the existing condition. The signal timing was optimized to achieve the best possible results for the 2022 conditions. A similar amount of green time within the cycle was maintained for the CR 72 approaches and a similar amount of average delay and LOS D operations result. Optimizing the timing necessitated increasing the cycle length and the green time for the US 40 approaches. The average delays double for the westbound through movement and triple for the eastbound through movement. The delay for the left-turn movements from US 40 also increases significantly compared to the existing conditions. The corresponding levels of service drop from LOS B/C to LOS D. Despite the volume increase from existing conditions, the LOS remains acceptable because the full demand cannot reach the intersection in the peak hour. Additional delay encountered by the cross street drivers at each intersection prevents the full demand from accessing US 40 in the peak hour and lowers the corridor throughput, resulting in a lower service volume at the intersection. The Rendezvous Road intersection also experiences a decrease, to LOS C. The effect of the additional volume is evidenced by the increase in average delay for the westbound through movement from 3 seconds to 44 seconds per vehicle.

The through-movement queue lengths on US 40 increase significantly at the CR 72 intersection with average lengths between 0.5 and 0.75 mile. The westbound queue is longer than the eastbound queue because the westbound through movement queues past and blocks access to the westbound right turn pocket, increasing the delay for this movement and adding to the queue length. The westbound right turn volume is 155 vehicles higher in the peak hour than the eastbound right turn volume. These longer queue lengths at CR 72 contribute to the increased travel time through the corridor. The excessive delay at the Old Victory Road intersection can be attributed to the westbound queue from CR 72 and the additional volume traveling through the intersection due to the adjacent Grand Park housing developments. This queue likely blocks the three existing driveways on the north side of US 40 for most of the peak hour. The longest average queue length at the Rendezvous Road intersection is 280 feet for the westbound through movement and reaches 830 feet for the 95-percentile queue length. This movement experiences the highest average delay with 44 seconds per vehicle.

The demand constriction on US 40 is evidenced by the high delays and low levels of service shown in **Table 5** for the unsignalized intersections. Most of the unsignalized intersections are projected to operate at unacceptable LOS E and F during the peak hour because the additional volume on US 40 reduces the available turning gaps. The capacity constrictions for this volume result in dense platooning of through movement vehicles on US 40. It is logical to assume drivers will not tolerate these levels of delay that are measured in minutes rather than seconds as in the Existing Conditions scenario and would seek other routes or access locations to US 40. However, the roadway network on the south side of US 40 is constrained by the railroad tracks and there are few feasible options for drivers to reroute.

The average delay for turn movements at the Eisenhower Drive intersection is so much higher than adjacent intersections because the volumes are greater (the traffic impact studies for the developments distribute volume to this intersection because Eisenhower Drive has an at-grade railroad crossing). The highest individual movement delay is the right-turn from Eisenhower Drive to eastbound US 40 at 483 seconds, or 8 minutes, per vehicle. This long delay partially results from the eastbound queues at the CR 72 intersection. The right-turn pocket is approximately 75 feet long, so the approach effectively functions as a 1 lane approach shared by the left- and right-turn movements because the left-turn queues block access to the right-turn pocket during most of the peak hour. The Byers Avenue right-turn movement is subject to this same queue issue but, unlike the Eisenhower Drive approach to US 40, has a lower average delay because the left-turn volume is not as large. Some traffic analysis documentation caps the seconds of delay reported for analysis results to a more realistic value that is reflective of how long a driver may choose to wait. However, this documentation presents the actual results as output by Vissim to allow a comparison between the various conditions and scenarios.

5.3 Year 2045 No Build Scenario

This scenario uses volumes that incorporate forecasted background traffic growth and trips generated by approved development expected to be complete between years 2019 and 2045. The study area network adds developer-committed intersection improvements to the Year 2022 Existing Plus Committed Interim Condition. The forecasts do not account for a Fraser Valley Parkway facility.

As **Table 6** shows, the intersection delay and levels of service continue to deteriorate from those experienced in the Year 2022 Existing Plus Committed Interim Condition. The increased volume on the existing roadway network results in near saturation conditions for the corridor limits. The CR 72 intersection experiences additional overall average delay per vehicle, but still operates acceptably at LOS D overall (there are two individual movements that operate at LOS E, the northbound through and eastbound left). This acceptable LOS is primarily due to the LOS D operations for the US 40 through movement (the largest-volume movements) and is again attributable to constrictions along the corridor

that prevent the full demand volume from reaching the intersection in the peak hour. Like Year 2022 Existing Plus Committed Interim Condition, the segments downstream of the CR 72 intersection in each direction experience travel times and speeds similar to the existing condition. This signalized intersection serves to meter traffic and limit the downstream service volume. The upstream segments, however, experience additional delay and slower speeds due to volume demand that exceeds capacity of the roadway, resulting in travel times that are about 50 percent greater than in the year 2022 and nearly four times greater than year 2019. The through-movement queue lengths extend nearly 1 mile upstream. This queue impacts movements between US 40 and the additional full-movement, unsignalized intersection 14E PA for the Rendezvous development and contributes to the LOS F operations in the peak hour.

Table 6. Year 2045 No Build Scenario Level of Service Results

Intersection	2045 No Build		
	Traffic Control	Delay (sec/veh)	LOS
US 40/CR 5	TWSC	510	F
US 40/CR 8	TWSC	2401	F
US 40/Eisenhower Drive	TWSC	2131	F
US 40/Byers Avenue	TWSC	195	F
US 40/Clayton Avenue	TWSC	19	C
US 40/CR 72	Signal	40	D
US 40/Johns Drive	TWSC	45	E
US 40/Old Victory Road	TWSC	1247	F
US 40/Meadows	TWSC	23	C
US 40/14E PA Access	TWSC	247	F
US 40/Fire Station Access	TWSC	91	F
US 40/Rendezvous Road	Signal	212	F

Note:

Bold text indicates a primary intersection.

At the Rendezvous Road intersection, the average queue length and the 95-percentile queue length are both approximately 3,200 feet in the westbound direction, suggesting saturation for nearly the whole peak hour. This queue length is likely attributable to the narrowing of US 40 from two lanes to one lane per direction upstream of this intersection. The delay at this intersection also serves to meter westbound traffic entering the corridor and reduces the volume approaching the CR 72 intersection. This effect is not evident in the year 2022, with lower background volumes and fewer completed developments adding to the demand for US 40.

The delays for the stop-controlled side street movements are worse than 2022 due to the additional development-generated trips accessing these intersections and the volume increase on US 40 providing fewer turning gaps. These conditions, which predict delays of several minutes in the peak hour, are exacerbated by the lack of feasible options from the south side of US 40 to access the highway and the preponderance of the development occurring on this side of the highway. At the CR 5 intersection, the eastbound through movement experiences an average delay of 227 seconds per vehicle. Delay for this free-flowing movement, which is not subject to stop control, indicates a lack of capacity on the 2-lane highway prior to entering Fraser.

5.4 Year 2045 Build Scenario with Roundabouts (Alternative 1)

This scenario uses the same volumes and access locations as the 2045 no build and build with traffic signals scenarios. The study area network reflects an additional travel lane in each direction on US 40 but does not account for a Fraser Valley Parkway facility. The network also includes the fourth approach to the Rendezvous Road intersection. Roundabout control is included for the CR 5, CR 8, and CR 72 intersections with US 40, and signal control is included for the Eisenhower Road and Old Victory Road intersections, which are unsignalized in the no build scenario. **Exhibit 15** depicts this roadway network.

As **Table 7** shows, the conversion of the CR 5, CR 8, and CR 72 intersections to roundabouts has varying impacts along the corridor. The two county road intersections at the west end of the corridor operate very well overall at LOS B in the peak hour. However, as **Table 11** shows, the northbound left- and right-turn movements from CR 5 both experience average delays of 45 seconds per vehicle. These LOS D operations result because the eastbound through movement demand volume in the peak hour creates a steady stream of traffic through the roundabout with few gaps through which to enter the roundabout from the side streets. The southbound left- and right-turn movements at CR 8 experience this same issue, but the lower volumes contribute to a per-vehicle average delay that is about half that for CR 5. At both roundabouts, the eastbound through movement delay is greater than for the westbound through movement; this is attributable to a higher approach speed for the eastbound direction as drivers enter the study corridor from Tabernash. The westbound drivers are already operating at a lower speed due to navigating the congestion and intersections within the study area, and the entering volume is lower because of capacity constrictions upstream through the study area to the Rendezvous Road intersection.

Table 7. Year 2045 Build Scenario with Roundabouts Level of Service Results



Intersection	2045 Roundabouts (Alternative 1)		
	Traffic Control	Delay (sec/veh)	LOS
US 40/CR 5	Roundabout	10	B
US 40/CR 8	Roundabout	14	B
US 40/Eisenhower Drive	Signal	47	D
US 40/Byers Avenue	TWSC	81	F
US 40/Clayton Avenue	TWSC	14	B
US 40/CR 72	Roundabout	147	F
US 40/Johns Drive	TWSC	57	F
US 40/Old Victory Road	Signal	50	D
US 40/Meadows	TWSC	14	B
US 40/14E PA Access	TWSC	155	F
US 40/Fire Station Access	TWSC	10	A
US 40/Rendezvous Road	Signal	82	F

Note:

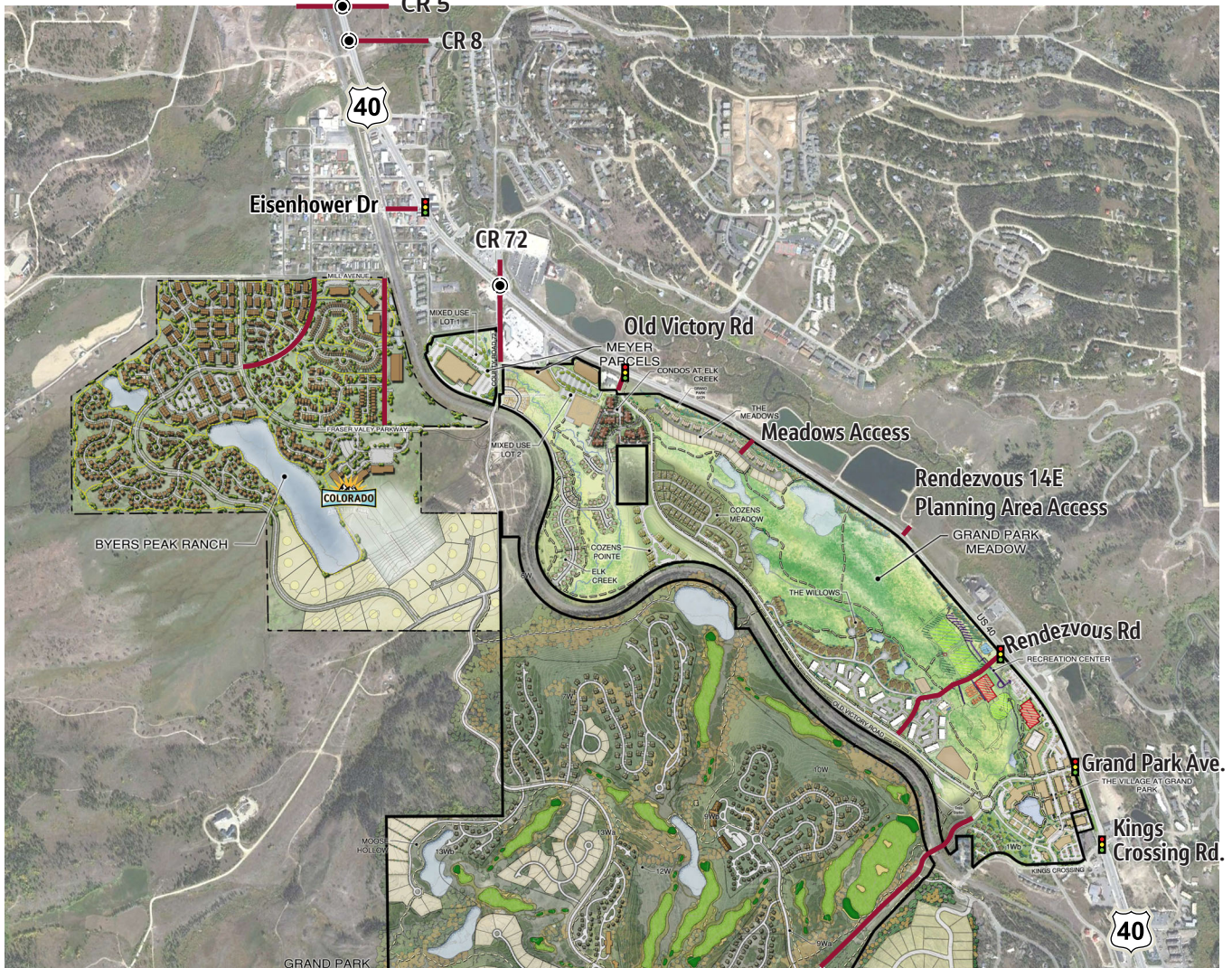
Bold text indicates a primary intersection.



LEGEND

- Proposed Roadway
-  Existing or Proposed Traffic Signal
-  Proposed Roundabout

**Exhibit 15. 2045 Build Scenario Roundabouts
Alternative Roadway Network
CDOT Region 3
US 40 – Fraser**

The roundabout at CR 72 operates unacceptably at LOS F and causes unsignalized intersections adjacent to the roundabout approaches to operate with LOS F conditions. However, the Clayton Avenue intersection operates well because the poor operations for the westbound through movement at CR 72 meter the departure volume and gaps are provided for the right-out turning movements. The constant flow of through traffic on US 40 results in moderate delays of 43 and 27 seconds per vehicle, respectively, for the eastbound and westbound movements, but excessive delay for CR 72 movements because this constant flow limits opportunities to enter the roundabout. As a result, the average delay is measured in seconds for the US 40 movements and minutes for the CR 72 movements. These delays produce average queue lengths of 990 feet in the eastbound direction and 1,465 feet in the westbound direction on US 40, and nearly one-half mile in each direction on CR 72. Queues of this length will impact access locations and operations on CR 72. The addition of signals at Eisenhower Drive and Old Victory Road improves the operations as compared to the no build scenario because gaps are provided for the turning movements. However, the delay is greater by incorporating roundabouts rather than implementing the signals alternative and the operations at the Eisenhower signal decrease because of the CR 72 eastbound approach queue and the operations at the Old Victory Road signal decrease because of the westbound approach queue.

At the east end of the corridor, the Rendezvous Road intersection experiences additional delay with the roundabout control at CR 72 and as a result, queues on the westbound CR 72 approach spill back to this intersection and prevent the westbound demand at Rendezvous Road from being fully serviced. LOS F conditions and lengthy queues for the westbound Rendezvous Road approach result in the peak hour. The average and 95-percentile queues are nearly equal, indicating this condition perpetuates throughout most of the peak hour. These CR 72 queues also impact the operations for the 14E PA access intersection.

5.5 Year 2045 Build Scenario with Traffic Signals (Alternative 2)

This scenario uses the same volumes and access locations as the 2045 No Build Scenario. The study area network reflects an additional travel lane in each direction on US 40 but does not account for a Fraser Valley Parkway facility. The network also includes the fourth approach to the Rendezvous Road intersection. Signal control is also included for the CR 5, CR 8, Eisenhower Road, and Old Victory Road intersections with US 40, which are unsignalized in the no build scenario. **Exhibit 16** depicts this roadway network.

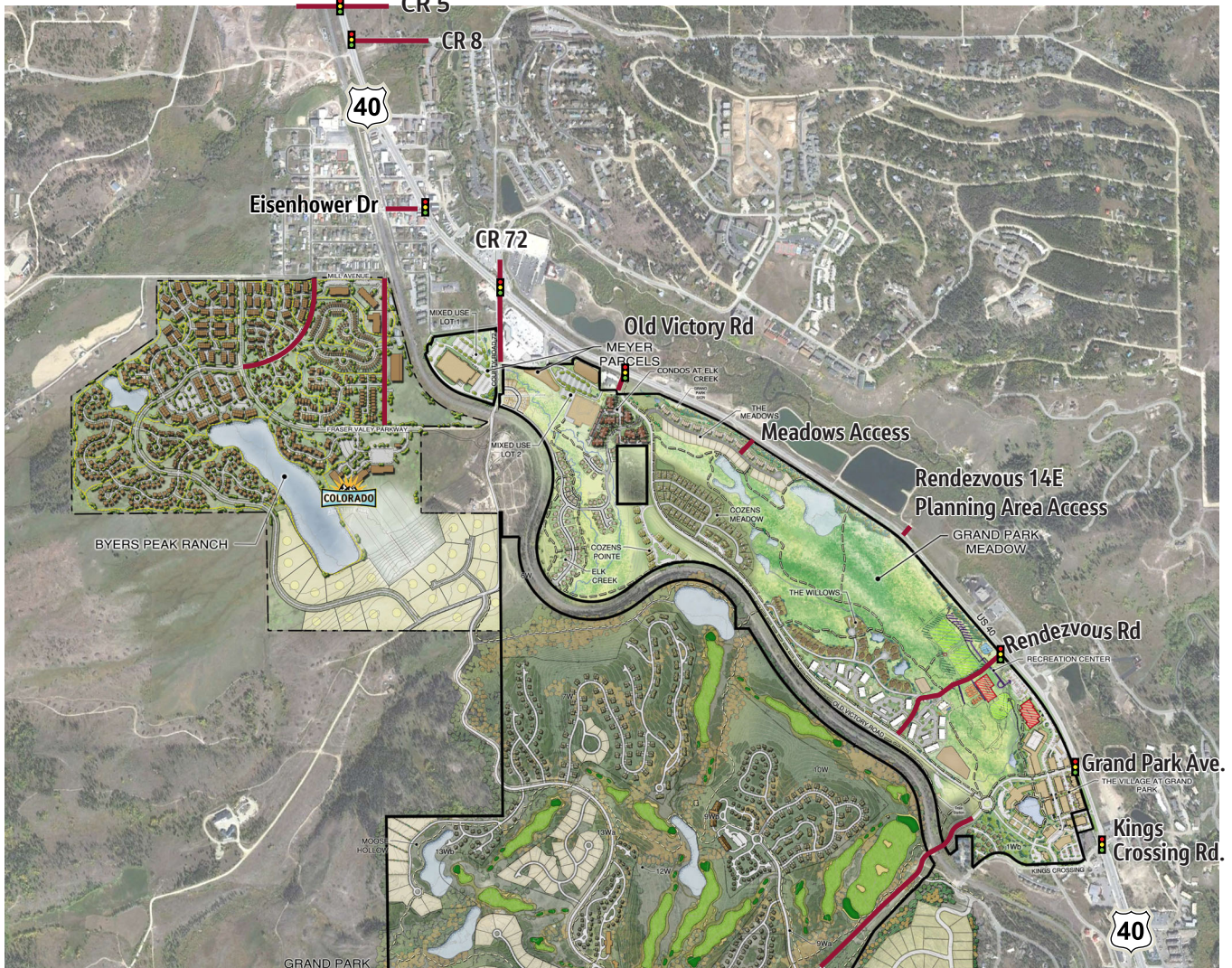

LEGEND

- Proposed Roadway
- Existing or Proposed Traffic Signal

**Exhibit 16. 2045 Build Scenario Traffic Signals
Alternative Roadway Network
CDOT Region 3
US 40 – Fraser**

As **Table 8** shows, all of the intersections except Rendezvous Road and Byers Avenue operate at an acceptable level of service with two lanes per direction and traffic signal control at the three County Road intersections. The average travel times decrease by half and corresponding speeds double over the no build condition because of the addition of the through lanes and these traffic signals. However, the segments downstream of CR 72 in both directions experience slight increases in travel time and slightly lower speeds than no build. This occurs because the improved CR 72 intersection configuration does not meter traffic as is the case with the no build scenario.

Table 8. Year 2045 Build Scenario with Traffic Signals Level of Service Results

Intersection	2045 Traffic Signals (Alternative 2)		
	Traffic Control	Delay (sec/veh)	LOS
US 40/CR 5	Signal	36	D
US 40/CR 8	Signal	12	B
US 40/Eisenhower Drive	Signal	8	A
US 40/Byers Avenue	TWSC	36	E
US 40/Clayton Avenue	TWSC	26	D
US 40/CR 72	Signal	44	D
US 40/Johns Drive	TWSC	21	C
US 40/Old Victory Road	Signal	13	B
US 40/Meadows	TWSC	21	C
US 40/14E PA Access	TWSC	24	C
US 40/Fire Station Access	TWSC	20	C
US 40/Rendezvous Road	Signal	76	E

Note:

Bold text indicates a primary intersection.

The CR 72 intersection experiences additional overall average delay per vehicle compared to the no build scenario, but still operates acceptably at LOS D. The protected/permissive left-turn phasing results in average delays of less than 1 minute for each left-turning vehicle and queue lengths that are accommodated by the existing left-turn lanes. The delay increases over the no build scenario because the additional capacity and improved traffic flow allow more volume to access the intersection during the peak hour. The average through movement queues extend 390 feet upstream in the eastbound direction and 685 feet in the westbound direction. The through movement queues extend past and block access to the westbound right turn pocket, increasing the delay for this movement adding to the queue length. The optimized cycle length is 150 seconds at this intersection. This long cycle is necessary to provide adequate green time for pedestrians. The shorter westbound queue would not extend to the 14E PA Access intersection, and the operations at this location would operate acceptably at LOS C in the peak hour.

The operations of the Rendezvous Road intersection improve over the no build scenario but are still an unacceptable LOS E in the peak hour. With a nearly 3,000-vehicle demand for the westbound approach, the demand is starting to reach hourly capacity for a signalized intersection. The delay results in average queue lengths of 3,100 feet. This unserved demand and queue spill back during the peak hour partially meters westbound traffic volume through the corridor.

The cross-street intersection delay decreases for the stop-controlled intersections compared to the no build scenario because the increased highway capacity and additional traffic signals produce gaps in the traffic stream that enable turning movements to occur more quickly. For example, the left-turn movement delay from Byers Avenue reduces significantly from 103 seconds to 36 seconds. In addition, provision of signal control at CR 5 and CR 8 reduces the time spent waiting to turn between these roads and the highway.

The average travel times for the whole corridor would be 35 percent lower in the eastbound direction and 47 percent lower in the westbound direction than the roundabouts alternative. The signal control at CR 72 results in less delay, which then results a lower travel time through the whole corridor. With a roundabout, every vehicle slows down to navigate the roundabout geometry, whereas some portion of the traffic stream does not encounter delay if drivers do not have to stop for a red signal indication. The faster travel time is also attributed to signal control processing more vehicles through the intersection in the peak hour.

5.6 Comparison of Year 2045 Build Scenarios Alternatives 1 and 2

Both build alternatives provide better operations than the no build scenario. Overall, the traffic signal build alternative operates better than the roundabout build alternative in the peak hour when comparing delay, travel time, and queue lengths. The signal alternative yields better operations at the CR 72 intersection than a roundabout configuration that provides an average overall vehicular delay of 147 seconds and LOS F peak hour operating conditions. The delay is primarily experienced on the cross street and results in queues on CR 72 that impact adjacent land uses and prevent the full peak hour demand from accessing the highway. The lengthy queues on US 40 result from the demand and requirement for drivers to slow considerably to navigate the roundabout. The US 40 queues are shorter with a signal.

The CR 5 and CR 8 roundabouts at the west end of the corridor operate very well and better than traffic signal control for the US 40 through movements. This is likely attributable to a lower westbound volume being able to access these intersections as a result of the excessive delay at the CR 72 roundabout. Likewise, the eastbound demand is constrained as a result of the limited capacity of one lane in each direction on US 40, west of CR 5. These two roundabouts may not operate quite as well with a traffic signal at CR 72, which would process more volume in the peak hour than a roundabout. This high level of service for US 40 is provided at the expense of higher delay and lower levels of service for the County Road approaches to these two roundabouts.

The roundabout alternative for CR 72 results in lower levels of service for the upstream intersections to the east of this cross street. The 0.25-mile long westbound approach queue spills into the Old Victory Road intersection and causes a drop from LOS B with a signal to LOS D with a roundabout. The Rendezvous Road intersection LOS decreases from E to F with a CR 72 roundabout primarily because of the unmet demand for westbound CR 72 that causes this queue to spill back to Rendezvous Road. Even though the type of control is the same in both alternatives for the Rendezvous Road intersection, operations are worse in the roundabout alternative because of queue spillback from the CR 72 roundabout.

The roundabout and traffic signal alternatives both have shorter corridor travel times compared to the no build scenario. The traffic signal alternative corridor travel time of 4.2 minutes in the westbound direction is 3.8 minutes less than the roundabout, which is primarily due to the lower delay and shorter queue lengths provided with signal control. The travel time difference is not as great in the eastbound direction for which the traffic signal alternative average is 4.5 minutes and the roundabout average is 7.0 minutes.

In general, queue lengths are longer at each location with the roundabout alternative. Traffic signal control results in shorter queues for all four approaches at the CR 72 intersection. Longer queues at this intersection impact operations upstream in both directions. Queues persist for most of the peak hour on the CR 72 approaches, which constrains volume from reaching the rest of the corridor network. Queuing on US 40 in the roundabout alternative spills back to Rendezvous Road in the westbound direction because this configuration is not adequate to handle the demand.

5.7 Year 2045 Build Scenario with Refined Traffic Signals Alternative

Once determined that neither Alternative 1 nor Alternative 2 would provide adequate levels of service through the study area, various combinations of the two alternatives were analyzed. Traffic signals at Eisenhower Drive, Old Victory Road, and Rendezvous Road were constant in each of these combinations while the type of control varied at the CR 5, CR 8, and CR 72 intersections. The Vissim models predicted similar traffic operations and poor levels of service from these combinations. The forecasted volumes and right-of-way considerations are not conducive to using roundabouts as the type of control at these intersections. Therefore, roundabouts were eliminated from further consideration based on these results and discussions with CDOT, Town of Fraser, and Grand County.

A third alternative, Year 2045 Refined Traffic Signals, moved forward as the remaining alternative for use in completing the traffic analysis. The intent of this alternative was two-fold:

- Refine the Build Scenario with Traffic Signals (Alternative 2) by incorporating various elements that optimize the performance of each County Road intersection.
- Incorporate bicyclist/pedestrian crossings required by trail network revisions identified later in the study process.

To determine these elements, various combinations of lane configurations, signal timing schemes, and pedestrian crossing treatments were assessed. The final version of this alternative represents the best possible level of service and operations that could be provided in 2045 with the predicted roadway network and volume conditions.

5.7.1 Composition of the Refined Traffic Signals Alternative

The following list discusses the elements assessed and notes those that were ultimately incorporated into the final version of the Year 2045 Refined Traffic Signals Alternative:

- CR 5 – A consistent 4-lane cross section along US 40 has been identified as a need, and the effort to widen US 40 to four lanes shall continue to advance west as funding allows into the future. Two lanes per direction for US 40 at the western limit of the study area were incorporated into the final version of the alternative. Likewise, CR 5 eastbound right-turn acceleration and deceleration lanes were incorporated with lengths as required by Table 4-6 in the CDOT State Highway Access Code for the existing speed limits of 65 mph to the west of the intersection and 55 mph to the east.
- The proximity of the at-grade railroad crossing to the CR 5 intersection with US 40 merits interconnection between the crossing gates and the new signal at CR 5. Although not modeled in this traffic study or included in the final version of the alternative, the study team acknowledges this should be incorporated into the signal timing for this intersection.
- CR 8 – A continuous green tee intersection was incorporated into an initial version of the alternative to optimize flow through this intersection. Because this cross street intersects US 40 on the north side only, this configuration provides free-flow movement for eastbound traffic through the intersection and stops westbound traffic to accommodate the southbound left turn to eastbound US 40. Although

the average travel time decreased by approximately 0.5 minute for the eastbound direction, this configuration resulted in relatively little change in average overall delay for the intersection. Discussions with the Town of Fraser determined that a regional trail crossing for bicyclists and pedestrians is planned for this intersection, necessitating control for the eastbound movement to accommodate crossing time. Due to marginal operational benefit and the need for multi-modal accommodations, a traditional signalized intersection configuration was included in the final version of the alternative. The crosswalk is located on the west approach to avoid the conflict with the southbound to eastbound left turn movement and reduce overall delay for the intersection.

- CR 72 – Additional left-turn lanes were added to the CR 72 northbound and southbound approaches to shorten the cycle time for these movements and provide more capacity for the US 40 through movements. The projected volumes for the left turns from US 40 do not indicate a need to provide dual lanes. The dual left-turn lane configurations decreased movement delay and were incorporated into the final version of the alternative.
- Relocating the bicyclist/pedestrian crossing of US 40 to a grade separation was investigated. Removing this phasing from the signal cycle did lessen vehicular delay but did not improve operations enough to justify the cost and other impacts associated with grade-separation. The two existing crosswalks across US 40 were reduced to one located on the west approach of the intersection. The heavier left-turn volume is from southbound to eastbound, so locating the crosswalk on the west side reduces the conflict and provides more cycle time for the highest left-turn volume in the intersection. One crosswalk across US 40 and two crosswalks across CR 72 were incorporated into the final alternative.
- The signalized intersection to the north of the US 40 intersection at Wapiti Drive was incorporated into the final alternative. The proximity of these two signalized intersections along with the demand volume suggests their operations will likely impact each other. Inclusion of this signal in the model provided the opportunity to assess these impacts and coordinate the timing to optimize throughput for both intersections.
- Auxiliary Lane on WB US 40 – The effectiveness of a westbound auxiliary lane on US 40 between Rendezvous Road and CR 72 was tested to determine if it would improve traffic flow. The lane was introduced as a shared through/right-turn lane on the westbound approach to Rendezvous Road. Two versions of this lane were modelled to reflect dropping it as a right-turn-only lane to northbound CR 72 and at the 14E PA intersection. Per the Vissim results, this lane does address capacity issues at the Rendezvous Road intersection by allowing more westbound demand to enter the study limits within the peak hour. However, the roadway configuration downstream does not have the capacity to accommodate this additional demand and operational issues would result from excess queuing at the CR 72 and Old Victory Road intersections along with merging associated with the drop from three to two through lanes. Although delay and queuing issues would persist for the westbound approach to Rendezvous Road with only two through lanes, it would be more beneficial from a regional perspective to constrain the demand to the east of this intersection where access to a parallel facility may become available. This WB auxiliary lane was not carried forward into the final version of the alternative.
- Auxiliary Lane on EB US 40 – An eastbound auxiliary lane was tested for US 40 between the CR 72 and Old Victory Road intersections to facilitate the northbound to eastbound movement. This improved operations and was incorporated into the final alternative. An eastbound auxiliary lane to the east of Old Victory Road is not necessary (and was not tested) because the two accesses in this section (Meadows RIRO and Rendezvous Road right turn) have acceleration and deceleration lanes and are far enough apart that their operations do not impact each other.

- Rendezvous Road – This intersection currently provides westbound right-turn acceleration and deceleration lanes. The final version of the alternative includes eastbound right-turn acceleration and deceleration lanes to accommodate turns to and from the fourth approach on the south side of US 40 that is included in the Build scenario networks. Per the Access Code, these lengths were set at 310 feet for the deceleration lane and 270 feet for the acceleration lane, under the assumption that the posted speed limit will be 35 mph to match the existing condition.
- Cross-street Turn-lane Lengths – Individual turn movements from the side streets in Build Alternatives 1 and 2 showed lower LOS and higher delays, which could be attributed to being blocked from accessing the intersection by other movement queues on the approach. As this alternative is intended to maximize operations in the study area, turn-lane lengths appropriate to accommodate projected queues were carried forward into the final alternative.

5.7.2 Projected Operations

As **Table 9** shows, four intersections (three of which are signalized) are projected to operate with unacceptable LOS (below LOS D) in the year 2045 peak hour. In the westbound direction, the two through lanes entering the study limits do not provide enough capacity to serve the demand volume at the Rendezvous Road intersection. The LOS appears to be very good with lower amounts of average delay for the downstream intersections between Rendezvous Road and CR 72; however, this is a result of the constraint imposed by the lack of capacity at the Rendezvous Road intersection and a lower westbound volume approaching these intersections. When comparing these results to those in **Table 8** for the Traffic Signals Alternative 2, it appears that this Refined Traffic Signals Alternative would provide lower LOS and higher delay at most intersections despite the added improvements. However, this is the only alternative tested that included two eastbound through lanes for US 40 at the west end of the study area. A higher proportion of the peak hour demand volume can enter the study area network and the result is a 17 percent increase in demand served, or throughput, to 72 percent of the forecasted volume for the eastbound direction.

The effect of partially alleviating the capacity constraints imposed by the 1-lane-per-direction configuration is evident by the decrease in level of service from LOS D to LOS F for the CR 5 intersection with this Refined Traffic Signals Alternative. With a nearly 60-second increase per vehicle, this intersection experiences the most notable increase in overall average delay due to the increased demand. With the 1-lane configuration, the Vissim model recognizes a lower volume that is able to reach this intersection in the peak hour and does not account for the queue spillback outside of the model area. Therefore, additional lane capacity results in higher volume reaching the intersection and contributing to more additive delay associated with signal control.

The increased volume served also impacts the Byers Avenue intersection during the peak hour. The additional eastbound volume approaching CR 72 causes queue spillback to occur more frequently during the peak hour and impedes turning between this cross street and US 40. At the Eisenhower Drive intersection, the average delay for the left-turn movement to westbound US 40 increases from 33 to 70 seconds per vehicle in the peak hour because the companion right-turn movement's ability to turn right on red is severely restricted due to the higher eastbound demand at the CR 72 approach and the longer queues that result. The length of the right- and left-turn lanes was maximized between US 40 and Railroad Avenue.

Table 9. Year 2045 Build Scenario with Refined Traffic Signals Level of Service Results

Intersection	2045 Refined Traffic Signals Alternative		
	Traffic Control	Delay (sec/veh)	LOS
US 40/CR 5	Signal	90	F
US 40/CR 8	Signal	54	D
US 40/Eisenhower Drive	Signal	61	E
US 40/Byers Avenue	TWSC	44	E
US 40/Clayton Avenue	TWSC	22	C
US 40/CR 72	Signal	41	D
US 40/Johns Drive	TWSC	26	D
US 40/Old Victory Road	Signal	17	B
US 40/Meadows	TWSC	6	A
US 40/14E PA Access	TWSC	32	D
US 40/Fire Station Access	TWSC	24	C
US 40/Rendezvous Road	Signal	67	E
CR 72/Wapiti Drive	Signal	15	B

Note:

Bold text indicates a primary intersection.

The addition of the second eastbound through lane had virtually no impact on the traffic flow and operations for the westbound demand. The westbound demand entering the study limits at the Rendezvous Road intersection is constrained and not all the demand enters the network during the peak hour. The demand approaches the capacity of this signalized intersection and the result is LOS E operating conditions with an average vehicular delay of 67 seconds. As shown in **Table 11**, the highest movement delay is for the westbound left-turn with nearly 3 minutes of average delay during the peak hour. The unsignalized access points experience higher delays due to lack of available gaps in the traffic stream for turning.

The Wapiti Drive intersection with CR 72 is projected to operate with acceptable LOS in the peak hour. Southbound queues at the US 40 approach did not extend into this intersection and do not appear to impact the operations of this intersection.

5.7.3 Driveways Between the Lions Ponds and Old Victory Road

Three unsignalized driveways provide access to the north side of US 40 for existing businesses and proposed townhome residences between the Lions Ponds and the Old Victory Road intersection with US 40. The closest driveway is approximately 450 feet upstream of the intersection and the middle driveway (a companion driveway serving the same retail land use), an additional 180 feet from the intersection. The furthest driveway is located approximately 930 feet prior to the intersection and serves a commercial center and a proposed townhome development. None of these accesses have existing westbound right-turn acceleration or deceleration lanes. A queuing analysis was performed with the Year 2045 Refined Traffic Signals Alternative to determine if westbound through movement queues for the Old Victory Road intersection would extend past these access points and effectively eliminate peak hour left

in/out access that is provided in the existing condition. The modelling predicts an average queue length of 320 feet with a 95th-percentile queue length of 685 feet in the peak hour. While the two companion driveways are within the 95th-percentile queue length, neither are likely to be consistently blocked by queues during the peak hour.

5.8 Year 2022 Existing Plus Committed Interim Condition Volumes with Refined Traffic Signals Alternative Roadway Network

The final Vissim model was produced to analyze the Year 2022 Existing Plus Committed Interim Condition forecast volumes with the Refined Traffic Signals Alternative roadway network that includes four lanes and six signalized intersections. As **Table 10** shows, the proposed improvements would provide desirable levels of service at every intersection during the peak hour. The side-street movements would have adequate gaps through which to turn to and from US 40. The signalized intersections could be timed to provide progression along US 40 and minimize delay to the through movements. With the highest cross street demand, CR 72 experiences the highest average delay of all the signalized intersections.

Table 10. Year 2022 Existing Plus Committed Interim Condition with Refined Traffic Signals Alternative Roadway Network Level of Service Results

Intersection	2022 Refined Traffic Signals Alternative		
	Traffic Control	Delay (sec/veh)	LOS
US 40/CR 5	Signal	7	A
US 40/CR 8	Signal	9	A
US 40/Eisenhower Drive	Signal	6	A
US 40/Byers Avenue	TWSC	15	B
US 40/Clayton Avenue	TWSC	10	A/B
US 40/CR 72	Signal	24	C
US 40/Johns Drive	TWSC	5	A
US 40/Old Victory Road	Signal	7	A
US 40/Meadows	TWSC	6	A
US 40/Fire Station Access	TWSC	1	A
US 40/Rendezvous Road	Signal	5	A
CR 72/Wapiti Drive	Signal	11	B

Note:

Bold text indicates a primary intersection.

5.9 Projected Operations Summary

Table 11 summarizes the delay and level of service projections from the Vissim models by movement for each intersection in every condition and scenario. The preceding subsections discuss these location-specific measures of effectiveness.

Table 11. Intersection Delay and Level of Service Summary

Int Name	Appr	Mvmt	2019 Existing			2022 Existing + Committed			2045 No Build			2045 Alt 1 - Roundabouts			2045 Alt 2 - Signals			2045 Refined Signals			2022 Refined Signals					
			Traffic Control	Demand Volume (veh/hr)	Delay (sec/veh)	LOS	Traffic Control	Demand Volume (veh/hr)	Delay (sec/veh)	LOS	Traffic Control	Demand Volume (veh/hr)	Delay (sec/veh)	LOS	Traffic Control	Demand Volume (veh/hr)	Delay (sec/veh)	LOS	Traffic Control	Demand Volume (veh/hr)	Delay (sec/veh)	LOS	Traffic Control	Demand Volume (veh/hr)	Delay (sec/veh)	LOS
US 40/CR 5	WB	LT		155	1		110	1		155	1		155	4		195	63		195	64		110	50			
		TH		645	1		970	0		2170	0		2170	3		2170	5		2170	8		970	3			
		RT		5	1		5	1		5	1		5	4		5	2		5	3		5	3			
	NB	Total		730			1085			2370			2370			2370			2370			1085				
		LT		10	8		15	12		60	466		60	45		60	70		60	75		15	75			
		TH		0	0		0	0		0	0		0	0		0	0		0	0		0	0			
	EB	RT		95	8		125	13		215	510		215	45		215	1		215	7		125	6			
		Total		105			140			275			275			275			275			140				
		LT		5	4		5	20		5	223		5	15		5	137		5	197		5	72			
	SB	TH		555	0		905	7		2360	223		2360	11		2360	80		2360	195		905	5			
		RT		20	1		25	4		80	184		80	11		80	71		80	128		25	2			
		Total		580			935			2445			2445			2445			2445			935				
Int	LT		5	10		0	0		0	0		0	0		5	72		5	91		5	77				
	TH		0	0		0	0		0	0		0	0		0	0		0	0		0	0				
	RT		0	0		0	0		0	0		0	0		0	0		0	0		0	0				
Total		5			5			5			5			5			5			5						
Total		1420	10.4	B	2165	34.2	D	5295	510.1	F	5995	10.2	B	5995	36.0	D	5995	90.3	F	2165	7.2	A				
US 40/CR 8	WB	LT		700	1		1050	1		2320	1		2320	6		2320	12		2320	15		1050	7			
		TH		80	2		85	2		125	2		125	7		125	5		125	6		85	3			
		RT		780			2445			2445			2445			2445			2445			780				
	NB	Total		780			2445			2445			2445			2445			2445			780				
		LT		25	6		25	30		50	91		50	20		50	75		50	124		25	92			
		TH		630	0		1010	26		2530	103		2530	19		2530	2		2530	98		1010	3			
	EB	RT		665			1035			2580			2580			2580			2580			665				
		Total		665			1035			2580			2580			2580			2580			665				
		LT		90	14		140	129		140	2367		140	29		140	88		140	63		90	58			
	SB	TH		30	12		35	115		50	2401		50	24		50	71		50	48		35	36			
		RT		120			125			190			190			190			190			125				
		Total		120			125			190			190			190			190			125				
Total		1555	13.9	B	2295	129.0	F	5215	2400.8	F	5215	13.8	B	5215	12.2	B	5215	54.3	D	2295	8.7	A				
US 40/Eisenhower Dr	WB	LT		65	4		70	19		115	26		115	35		115	40		115	69		70	81			
		TH		745	0		1095	0		2400	0		2400	5		2400	4		2400	1		1095	1			
		RT		810			2515			2515			2515			2515			2515			810				
	NB	Total		810			2515			2515			2515			2515			2515			810				
		LT		35	14		40	265		60	2009		60	29		60	33		60	70		40	72			
		TH		60	8		65	483		100	2131		100	25		100	12		100	45		65	6			
	EB	RT		95			105			160			160			160			160			95				
		Total		665			1040			2595			2595			2595			2595			665				
		LT		665	1		1040	73		2595	129		2595	87		2595	9		2595	125		665	4			
	Int	TH		55	1		60	40		95	79		95	74		95	3		95	114		60	2			
		RT		720			1100			2690			2690			2690			2690			720				
		Total		1625	14.0	B	2370	483.4	F	5365	2131.3	F	5365	46.7	D	5365	7.7	A	5365	61.5	E	2370	6.2	A		
US 40/Byers Ave/Clayton Ave	WB	LT		15	7		15	31		20	29		20	35		20	15		20	34		15	5			
		TH		805	1		1160	1		2485	1		2485	1		2485	5		2485	2		1160	1			
		RT		0	0		0	0		0	0		0	0		0	0		0	0		0	0			
	NB	Total		820			1175			2525			2525			2525			2525			820				
		LT		5	16		5	74		10	103		10	52		10	36		10	44		5	15			
		TH		15	13		20	97		20	195		20	81		20	21		20	18		20	6			
	EB	RT		20			25			30			30			30			30			20				
		Total		20			25			30			30			30			30			20				
		LT		5	10		5	28		20	44		20	22		20	22		20	0		5	0			
	SB	TH		720	1		1195	25		2670	29		2670	19		2670	2		2670	19		720	1			
		RT		5	1		5	19		5	25		5	15		5	1		5	10		5	1			
		Total		730			1205			2695			2695			2695			2695			730				
Int	LT		0	0		0	0		0	0		0	0		0	0		0	0		0	0				
	TH		5	10		5	11		20	19		20	14		20	28		20	22		5	10				
	RT		5			5			20			20			20			20			5					
Total		1575	15.9	C	2410	96.6	F	5270	195.0	F	5270	81.1	F	5270	36.2	E	5270	43.7	E	2410	15.0	B				
US 40/CR 72	WB	LT		55	15		115	35		220	47		220	28		220	31		220	75		115	66			
		TH		565	21		895	38		2125	36		2125	27		2125	25		2125	26		565	17			
		RT		165	1		265	7		320	8		320	26		320	5		320	4		165	1			
	NB	Total		785			1275			2665			2665			2665			2665			785				
		LT		95	34		115	33		185	50		185	50		185	67		185	91		95	72			
		TH		60	49		65	48		105	66		105	1263		105	62		105	79		65	71			
	EB	RT		55	1		100	1		175	3		175	3		175	6		175	3		55	1			
		Total		210			280			465			465			465			465			210				
		LT		120	18		125	48		170	55		170	42		170	43		170	101		125	54			

5.10 Measures of Effectiveness

MOEs were obtained from the Vissim model output to assess the projected operations of the analysis scenarios in the years 2022 and 2045. The results discussions in the preceding subsections of this chapter identified the location-specific MOEs related to level of service, delay, and queue length, and the corridor-wide MOE related to travel time to assist with understanding the impact of a no-build scenario and comparing the build scenario alternatives. Assessment of the MOEs determined that the build scenario Roundabouts and Traffic Signals alternatives would not be adequate to service the forecasted demand and led to the development of the Refined Traffic Signals Alternative, which is recommended for implementation. Sections 5.7 and 5.8 presented the location-specific MOEs for this alternative in years 2022 and 2045.

Table 12 shows the projected system-wide MOEs for the Refined Traffic Signal Alternative in years 2022 and 2045. The VMT are projected to be 7,279 miles in year 2022 and 13,388 miles in year 2045, within the study limits. This increase of approximately 84 percent is attributable to the additional demand volume traveling through the network. The additional miles traveled also contributes to the nearly four-fold increase in hours traveled. The VHT during the peak hour within the study limits are projected to be 211 hours in year 2022 and 793 hours in year 2045. The total network delay that is the sum of the delay for all vehicles that travel within the study limits during the peak hour is projected to be 50 hours in year 2022. By year 2045, this delay increases to 497 hours despite only 85 percent of the demand being served.

Table 12. Refined Traffic Signals Alternative System-wide Measures of Effectiveness

	2022 Refined Signals	2045 Refined Signals
Vehicle Miles Traveled	7,279	13,388
Vehicle Hours Traveled	211	793
Vehicle Hours Delay	50	497
Percent Demand Served	100%	85%

5.11 Summary of Conditions and Scenarios

Year 2019 Existing Conditions. The corridor operates at acceptable LOS and drivers can generally travel close to the posted speed limits. The full network demand is served during the peak hour.

Year 2022 Existing Plus Committed Interim Condition. Lower LOS at each intersection and travel times that are double the existing scenario are primarily attributable to the volume increase caused by development-generated traffic and not the background volume growth over the 3-year period from 2019 to 2022. Approximately 99 percent of the total demand within the study limits would be served during the peak hour.

Year 2045 No Build Scenario. Operating conditions approaching saturation for the entire peak hour result from increased background and development-generated volume on the existing roadway network. The travel times would be significantly worse if the cross street volumes weren't constrained and the demand was able to access US 40 within the peak hour. Approximately 48 percent of the total demand within the study limits would be served during the peak hour.

Year 2045 Build Scenario with Roundabouts (Alternative 1). The poor performance of a roundabout at the CR 72 intersection impacts the rest of the corridor and lower levels of service result for the adjacent intersections. The CR 5 and CR 8 roundabouts operate well due to a lower demand that results from the

metering effects caused by the poor performance of the CR 72 roundabout for the westbound direction and the lack of capacity west of the study area for the eastbound direction. Approximately 71 percent of the total demand within the study limits would be served during the peak hour.

Year 2045 Build Scenario with Traffic Signals (Alternative 2). The addition of signals at five intersections reduces delay and improves access to the highway for the cross streets, resulting in acceptable peak hour LOS for all intersections except Rendezvous Road. This is the most effective alternative among the 2045 scenarios and services the highest percentage of the volume demand. Approximately 74 percent of the total demand within the study limits would be served during the peak hour.

Volume Throughput for Year 2045 Build Scenario Alternatives 1 and 2. Demand volume is being constrained on US 40 at the entry points to the network. Although there is a total forecasted entering volume of 2,830 vehicles in the peak hour approaching Rendezvous Road on US 40 westbound, the Vissim model indicates a throughput of 2,100 vehicles, or 74 percent of the demand. In the eastbound, the forecasted entering volume approaching CR 5 is 2,445 vehicles in the peak hour whereas the network entering volume is 1,630 vehicles or 67 percent of the demand served. This issue likely occurs because US 40 eastbound enters the network as a single lane north of CR 5 before the widening begins near the CR 5 intersection. The forecast volume exceeds the hourly capacity of a single lane. With this much volume being constrained outside the network, the operational results of the study intersections are better than what they would be in a Synchro or Sidra deterministic analysis. For example, the Sidra results suggest the CR 5 roundabout would operate with a volume-to-capacity ratio of 1.92 based on the forecasted volume demand. This is a LOS F operating condition, whereas the capacity constraints accounted for in the Vissim model indicate LOS B operations at this intersection in the 2045 peak hour.

Year 2045 Build Scenario with Refined Traffic Signals Alternative. The refinements included in this alternative such as doubling the left-turn capacity for the CR 72 approaches, minimizing bicyclist/pedestrian crossing exposure, optimizing cross street turn lane lengths, and adding acceleration and deceleration lanes would improve operations and safety compared to the other Traffic Signal Alternative 2. However, the effect of increasing eastbound capacity and serving more of the peak hour demand overshadows these refinements and decreases performance through the study area (a lower service volume with the Traffic Signals Alternative allows the intersections to perform better and fewer drivers would experience less delay once they were in the study area). In the westbound direction, the two through lanes entering the study limits do not provide enough capacity to serve the demand volume at the Rendezvous Road intersection. Thus, significant queuing could occur along US 40 the east of this intersection. The LOS appears to be very good with lower amounts of average delay for the downstream intersections between Rendezvous Road and CR 72; however, this is a result of the constraint imposed by the lack of capacity at the Rendezvous Road intersection and a lower westbound volume approaching these intersections. Approximately 85 percent of the total demand within the study limits would be served during the peak hour. However, this alternative would result in less delay and higher LOS than the Year 2045 No Build Scenario. Comparing this alternative to the Roundabouts and Traffic Signals Alternatives 1 and 2 is not appropriate in that the additional eastbound through lane and the westbound auxiliary lane entering the study area change the conditions so significantly that an equal comparison is not possible.

Year 2022 Existing Plus Committed Interim Condition with Refined Traffic Signals Alternative Roadway Network. Once finalized with the various elements which would produce the highest possible volume throughput and intersection level of service for the horizon year 2045, a Vissim model was developed to assess this alternative with the Year 2022 Existing Plus Committed Interim Condition volumes. This scenario would provide acceptable levels of service and accommodate all the demand volume in the peak hour.

5.12 Level 1 Screening Conclusion

Assessing the projected performance of various alternatives and combinations of alternatives along with testing the effectiveness of individual elements led to the creation of the Year 2045 Refined Traffic Signals Alternative. This alternative is projected to provide the most ideal balance between intersection levels of service and volume throughput for the study corridor in year 2045 with the forecasted volumes. This alternative as defined in Section 5.7.1 will be carried forward into the Level 2 screening process, which will assess access modifications and the provision of frontage roads for local traffic that will work in concert with the US 40 recommended alternative to maximize traffic operational performance within the study limits.

5.13 Considerations for County Road 8 Road Closure

The turning movement volume forecasts are based on the data collection. Therefore, the variation from the typical distributions between CR 8 and US 40 noted in the existing conditions discussion was carried forward into the forecasts. The southbound left-turn volume forecast would be higher if based on more accurate counts at this intersection and the forecasted southbound left-turn movement at the CR 72 intersection would be lower. However, the total southbound to eastbound left turn volume forecast for these two cross streets is accounted for between these two intersections. Both movements are projected to operate similarly at LOS E in the year 2045 peak hour with approximately 63 seconds of delay. If the volume demand increases at CR 8, the delay would likely increase whereas the delay would decrease at CR 72. It is reasonable to assume drivers would divert back to CR 72 where there would be provision of two left-turn lanes and less delay. Thus, a natural equilibrium is likely to be reached between these two intersections.

There would also be right-turn and through movements that would vary between the two intersections. However, they represent a low enough proportion of the relevant movement volumes that revisions to signal phasing would not be required to account for them. All these rerouted movements were through movements at the Wapiti Drive intersection. Because this intersection is projected to operate at LOS B in year 2045 peak hour, this volume redistribution that would serve to reduce through movement volumes would not reduce operations. Due to the projected high levels of service at these two intersections, it is apparent that the projected traffic operations during the year 2022 peak hour would not be impacted by a redistribution between these two US 40 access points.

5.14 Capacity Considerations for US 40

The analyses of the year 2045 Build Scenario alternatives indicate that approximately 80 percent of the forecasted peak hour demand in the eastbound direction would be served with two eastbound lanes entering the network. Also, the full demand volume in the westbound direction cannot enter the study area due to the constraint caused by the Rendezvous Road intersection nor can it exit the study area within the peak hour due to the constraint caused by the CR 72 intersection. The demand from the side streets also contributes to a lower throughput within the corridor limits as it requires green time in the signal phasing. These issues arise because the forecasted demand volume approaching the study area exceeds the capacity for a 4-lane highway with at-grade intersections. A Capacity Assessment Sensitivity Test with the Vissim model (Section 3.4.4 explains the testing procedure) indicates that the cross section as proposed by the Year 2045 Refined Traffic Signals Alternative (four lanes and six signalized intersections) could provide LOS D intersection operations for US 40 and the side streets with a maximum entering volume of 2,065 vehicles at the west and 2,555 vehicles at the east study limit in the peak hour. Along with a proportionate reduction of the side street demand, these volumes represent approximately 85 percent of the year 2045 forecasted peak hour volume as shown previously in **Exhibit 10**. If the growth

in volume demand were to occur at the same rate each year, this amount of peak hour demand would be reached in Year 2038; however, the demand is primarily driven by development and is not likely to grow linearly. This amount of volume reduction is appropriate to accommodate through volume on US 40 in two lanes per direction, which is further benefitted from reduced volume on the side streets that require less green time in the signal phasing that can be redistributed to the US 40 through movements. Options to accommodate the excess demand should be considered to include alternative routes adjacent to US 40 at least through the length of the study area but ideally extending to the west and east of the study limits, a regional transit system, or limitations to adjacent land use development and growth.

5.15 Signal Warrant Analyses

The Refined Signals Alternative proposes new signals at four intersections with US 40 in the study area. Signal warrant analyses were conducted for these intersections to determine if they would be warranted per the FHWA *Manual on Uniform Traffic Control Devices for Streets and Highways* (MUTCD) in years 2022 and/or 2045. The TISs completed for the Byers Peak Ranch and Rendezvous/Grand Park developments suggest signals are warranted at Eisenhower Drive and Old Victory Road with projected years 2025 and 2040 volumes. However, the volume forecasts per this current study of US 40 differ from the forecasts in these TISs and merit re-evaluation of the warrants.

The MUTCD includes nine warrants to be considered when evaluating the need for a signal to control traffic at an intersection. This traffic study assessed the two warrants that are applicable to this study area: Eight-Hour Vehicular Volume (Warrant 1) and Four-Hour Vehicular Volume (Warrant 2). Although both warrants were assessed, in general an intersection will meet Warrant 2 if Warrant 1 is met.

The forecasts for the years 2022 and 2045 are for the midday peak hour. To determine the volumes for the other 3 or 7 hours required for the warrant analyses, the hourly proportions of volumes as identified from the July 13, 2019 24-hour data collection effort at each end of the study corridor were applied to the forecasted peak hour volumes at these four intersections. The data from the count collected north of CR 5 was used for the CR 5, County Road 8, and Eisenhower Drive intersections. The data from the count collected north of the Fire Station Access was used for the Old Victory Road intersection. The hourly data was collected for US 40 and not the side streets, so the analysis assumes the same proportion applies to the side streets. **Appendix F** contains a spreadsheet that shows the derivation of these volumes.

5.15.1 Eight-Hour Vehicular Volume (Warrant 1)

Exhibit 17 shows the Eight-Hour Vehicular Volume warrant table from MUTCD. The red shading indicates the target volumes for the warrant analyses. The following summarizes the results of the warrant analyses for each intersection:

- CR 5: Condition A is met in year 2022 for 12 hours with the projected Year 2022 Existing Plus Committed Interim Condition volumes. Condition B is also met for 15 hours. Therefore, a signal could be considered for installation by or within year 2022
- County Road 8: Condition A is met in year 2022 for 9 hours with the projected Year 2022 Existing Plus Committed Interim Condition volumes. Condition B is also met for 14 hours. Therefore, a signal could be considered for installation by or within year 2022
- Eisenhower Drive: Condition A is met in year 2022 for 8 hours with the projected Year 2022 Existing Plus Committed Interim Condition volumes. Condition B is also met for 13 hours. Therefore, a signal could be considered for installation by or within year 2022

- Old Victory Road: Condition A is met in year 2045 for 10 hours but is not met in year 2022. However, Condition B is applicable to this intersection in year 2022 because it does not have a large approach volume but, as the Vissim models indicate, the volume on US 40 would cause excessive delay. Condition B is met in year 2022 with the projected Year 2022 Existing Plus Committed Interim Condition volumes for 9 hours. Therefore, a signal could be considered for installation by or within year 2022. Condition B is met with year 2045 volumes for 14 hours.

5.15.2 Four-Hour Vehicular Volume (Warrant 2)

Exhibit 18 shows the Four-Hour Vehicular Volume warrant chart from MUTCD. The line that reflects two lanes on US 40 and one lane on the side streets was referenced for the analysis.

The following summarizes the results of the warrant analyses for each intersection:

- CR 5: This warrant is met in year 2022. In **Exhibit 18**, the blue dot indicates the lowest volume combination that meets the criterion and plots above the line. In total, the volume combination plots above the line for 12 hours in the year 2022. For most of these 13 hours, the year 2022 volumes far exceed the required minimums indicated by the line for two lanes on US 40 and one lane on CR 5
- County Road 8: This warrant is met in year 2022. The lowest CR 8 approach volume of 142 vehicles in an hour is similar to that for CR 5 (144 vehicles in an hour) and, therefore, the same dot represents both intersections in **Exhibit 18**. In total, the volume combination plots above the line for 11 hours in the year 2022. For most of these 11 hours, the year 2022 volumes far exceed the required minimums indicated by the line for two lanes on US 40 and one lane on County Road 8
- Eisenhower Drive: This warrant is met in year 2022. The red dot in **Exhibit 18** indicates the lowest volume combination that meets the criterion and plots above the line (120 vehicles in an hour). In total, the volume combination plots above the line for 11 hours in the year 2022. For most of these 11 hours, the year 2022 volumes far exceed the required minimums indicated by the line for two lanes on US 40 and one lane on Eisenhower Drive
- Old Victory Road: This warrant is met in year 2045 but not in year 2022. The lowest Old Victory Road approach volume of 142 vehicles in an hour is similar to that for CR 5 (144 vehicles in an hour) and, therefore, the same dot represents both intersections in **Exhibit 18**. In total, the volume combination plots above the line for 11 hours in the year 2045. For most of these 11 hours, the year 2045 volumes far exceed the required minimums indicated by the line for two lanes on US 40 and one lane on Old Victory Road

Table 4C-1. Warrant 1, Eight-Hour Vehicular Volume

Condition A—Minimum Vehicular Volume

Number of lanes for moving traffic on each approach		Vehicles per hour on major street (total of both approaches)				Vehicles per hour on higher-volume minor-street approach (one direction only)			
Major Street	Minor Street	100% ^a	80% ^b	70% ^c	56% ^d	100% ^a	80% ^b	70% ^c	56% ^d
1	1	500	400	350	280	150	120	105	84
2 or more	2 or more	600	480	420	336	150	120	105	84
2 or more	2 or more	600	480	420	336	200	160	140	112
1	1	500	400	350	280	200	160	140	112

Condition B—Interruption of Continuous Traffic

Number of lanes for moving traffic on each approach		Vehicles per hour on major street (total of both approaches)				Vehicles per hour on higher-volume minor-street approach (one direction only)			
Major Street	Minor Street	100% ^a	80% ^b	70% ^c	56% ^d	100% ^a	80% ^b	70% ^c	56% ^d
1	1	750	600	525	420	75	60	53	42
2 or more	1	900	720	630	504	75	60	53	42
2 or more	2 or more	900	720	630	504	100	80	70	56
1	2 or more	750	600	525	420	100	80	70	56

^a Basic minimum hourly volume

^b Used for combination of Conditions A and B after adequate trial of other remedial measures

^c May be used when the major street speed exceeds 40 mph or in an isolated community with a population of less than 10,000

^d May be used for combination of Conditions A and B after adequate trial of other remedial measures when the major-street speed exceeds 40 mph or in an isolated community with a population of less than 10,000

Exhibit 17. MUTCD Table 4C-1, Eight-Hour Vehicular Volume Warrant

Figure 4C-1. Warrant 2, Four-Hour Vehicular Volume

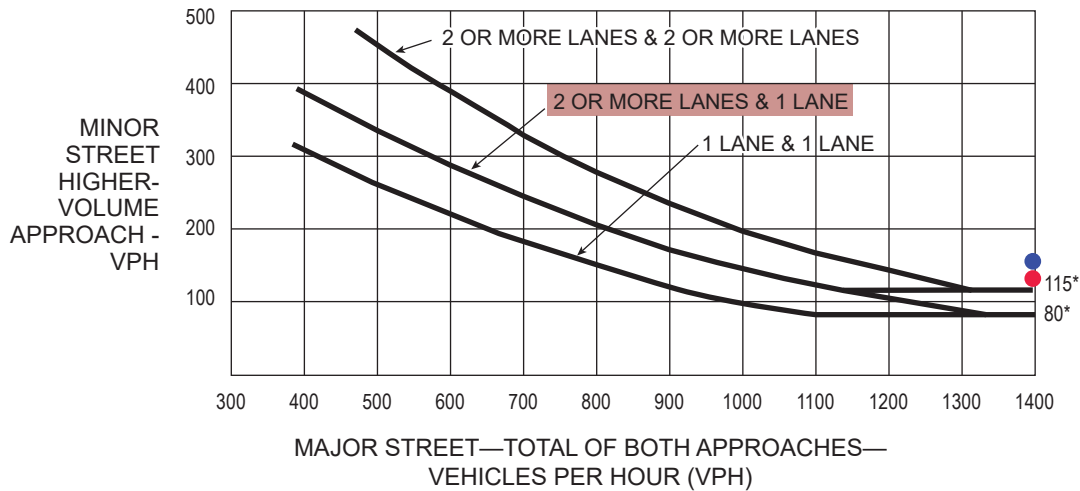

*Note; 115 vph applies as the lower threshold volume for a minor-street approach with two or more lanes and 80 vph applies as the lower threshold volume for a minor-street approach with one lane.

Exhibit 18. MUTCD Figure 4C-1, Four-Hour Vehicular Volume Warrant

6. Safety and Access

Traffic safety and operations are typically interrelated with access in urban areas. In acknowledgement of this, CDOT completed a safety and operations assessment of US 40 through the study area in support of this US 40 Fraser project. This chapter summarizes the findings of the assessment report. This chapter also discusses the potential for the Year 2045 Refined Traffic Signals Alternative to address the safety and access needs identified in the assessment report.

6.1 Summary of CDOT Safety and Operational Analysis Report, August 2019

Based on 5 years of crash data, the report related crash causality to roadway geometrics, traffic control devices, and traffic operations with the intent to develop strategies implementable with the widening effort that would address the identified safety issues. Per the report produced to document the assessment, the frequency and severity of roadway segment crashes in the corridor between CR 5 and Rendezvous Road (stated in the report to be approximately mileposts 226 through 228.89) is slightly below the expected values, resulting in a Level of Service of Safety (LOSS) II. A rating of LOSS II indicates there is low to moderate potential for crash reduction. The crash data exhibits predominate patterns of multiple-vehicle collisions, rear-end collisions, and crashes during frozen precipitation and icy road conditions. Rear-end collisions were the most common crash type along segments and accounted for 63 percent of the multiple-vehicle crashes as well as 43 percent of the crashes that occurred during weather events and 33 percent of the crashes that occurred on icy road surfaces.

Per the report, crashes were recorded at every intersection in the study area during the 5-year analysis period. The greatest number occurred at the CR 72 intersection, followed by the Rendezvous Road intersection. The CR 72 crashes result in a LOSS III for frequency and LOSS IV for severity, indicating moderate to high potential for crash reduction. Multiple-vehicle collisions accounted for 92 percent of the crashes at this intersection, 70 percent of which were rear-end collisions. The report acknowledges that this signal is functionally an isolated signal and recommends the incorporation of dilemma prevention timing with the use of advanced detection to reduce the potential for rear-end collisions. Another recommendation is to add side-mounted signal heads to the signal poles to improve visibility of the signal indications. The frequency and severity of the crashes at the Rendezvous Road intersection are at the expected value, resulting in a LOSS II rating and a low to moderate potential for crash reduction. Multiple-vehicle collisions represented 71 percent of the crashes, 54 percent of which were rear-end collisions. The report does not include recommendations to address this crash pattern.

The other study area intersections averaged less than one recorded crash per year. One of these was a vehicle-bicycle collision in the crosswalk at the Fraser Avenue intersection, resulting in injury. The report states the recent safety improvements should reduce the potential for future pedestrian/bicycle collisions and crashes in general through the section between Clayton and Park Avenues due to the reduction of allowed turning movements. Should the occurrence of pedestrian/bicycle collisions increase, the report recommends consideration of rectangular rapid flashing beacons on the warning sign assemblies or pedestrian hybrid beacons to enhance safety at crosswalks across US 40.

The operational analysis documentation for roadway segments states that the preliminary analysis conducted during the assessment indicates that the US 40 level of service is in the LOS C/D range for a 2-lane section. The report acknowledges that the level of service may be different during peak events on ski weekends. For the roadway segments between intersections, the report notes that the numerous speed limit changes may be difficult for drivers to comply with and recommends a speed study. Several

recommendations were provided to modify access locations through consolidation and closure, with the intent to reduce the number of conflict points along the roadway segments. Elimination of on-street parking is recommended to reduce the potential for the rear-end, same-direction sideswipe, and parked-vehicle collisions, which are overrepresented (they occur more often than expected for this type of facility). Finally, the report recommends consideration of the implementation of right-turn deceleration and acceleration lanes in lieu of a second through lane between CR 72 and Park Avenue. The documentation suggests that these lanes could reduce the potential for rear-end collisions and reduce delay, as right-turning vehicles would not block the through lane as drivers wait for pedestrians to complete crossing maneuvers on the side streets prior to completing their turns.

The report also included recommendations for each intersection. With the exception of Eisenhower Drive and CR 72, the report states that roundabouts are not likely to improve operations. It specifically recommends consideration of right-turn auxiliary lanes at the Park Avenue, Fraser Avenue, and Johns Drive intersections. The report addresses the adequacy of existing geometries at each intersection to accommodate heavy vehicles but recognizes that improvements within the existing urban context and right-of-way constraints are likely not practical at the locations that do not appropriately accommodate the necessary turning radii. The report suggests that four lanes at the CR 72 intersection would distribute volumes more evenly. General recommendations for both signalized intersections at CR 72 and Rendezvous Road are to revise the signal timing using current traffic counts (including adequate provision for pedestrian crossing time), increase the font size on the street name signs, and add dilemma protection to the signal cycle. Specific recommendations at CR 72 include eliminating one of the US 40 crosswalks to minimize conflict points, modifying the left-turn phasing to protected-only to improve pedestrian safety, adding emergency vehicle pre-emption if desirable, and improving illumination to facilitate detection. A specific recommendation at Rendezvous Road is to add detection if it is not present.

6.2 US 40 Access

The US 40 Fraser – Existing Access Book was developed during the conduct of this traffic study to summarize the following:

- Information related to existing and potential future access.
- Recommendations in the CDOT report.
- Locations and legends of speed limit signs.
- Right-of-way and city limits.
- Property and easement lines.
- Parcel ownership.
- Acceleration and deceleration lane lengths.
- Intersection control
- Allowed movements at intersections.

This access book may not be comprehensive but was produced with information available at the time. The intent is to assist with an assessment of access control on US 40 through the study area. The alternatives development process incorporated access modification recommendations from the CDOT report by referencing this book which is contained in **Appendix C**.

6.3 Potential for Refined Traffic Signals Alternative to Address Safety and Access Needs

All three alternatives developed for this traffic study incorporate recommendations from the CDOT report. However, not all the recommendations are included because the safety and operational assessment report was focused on current volumes and safety patterns with the intent to develop low-cost solutions that are easy to implement within a widening project. This traffic study is focused on accommodating future traffic volumes and operating conditions, so some of the CDOT recommendations are not applicable. For example, the traffic analysis has determined that a roundabout is not feasible to control traffic at the CR 72 intersection. Furthermore, one through lane per direction on US 40 will not be sufficient for the projected volumes

The Year 2045 Refined Traffic Signals Alternative proposes four new traffic signals at the CR 5, CR 8, Eisenhower Drive, and Old Victory Road intersections. The addition of these four signals to the existing CR 72 and Rendezvous Road signals would provide a corridor system of signalized traffic control through the study area, thereby enhancing driver expectation to encounter signals and providing the opportunity to coordinate well-balanced signal timing and traffic flow. Traffic signal coordination would contribute to a more homogeneous traffic stream. These elements would improve traffic flow which lowers levels of congestion and turbulence in the traffic stream and reduces the potential for multiple-vehicle crashes such as rear-end collisions. The platooning effect created by signal coordination provides gaps for side-street turns onto US 40 and reduces the potential for broadside collisions. The introduction of signals to existing unsignalized intersections sometimes increases crash occurrence initially, but this trend will subside and eventually cease as the traffic signal form of control becomes normal to drivers

This traffic study developed optimal signal timing at each intersection given the traffic and pedestrian/bicyclist volume forecasts and proposes full detection at each signalized intersection. With this proposed alternative, CR 72 no longer operates as an isolated signal and the CR 5 intersection would become the first signal encountered by eastbound drivers in several miles. Advance detection and dilemma protection timing would be appropriate for incorporation into this signal timing to reduce the potential for rear-end collisions. The timing of this signal is also recommended to include interconnection with the adjacent at-grade railroad crossing to reduce the potential for vehicle-train collisions that can occur if a vehicle is stopped on the tracks when a train is approaching.

The additional signals provide the opportunity for controlled pedestrian/bicyclists crossing movements, which would facilitate connections to the regional trail network on each side of US 40. The protected-only left-turn phasing at County Road 72 as proposed in this alternative would enhance pedestrian safety as recommended in the CDOT report. Also suggested in the report, the alternative reduces one crosswalk on US 40, which has the benefit of reducing conflict points and aiding with optimizing the signal timing.

Geometric features incorporated into the Year 2045 Refined Signals Alternative also support enhancing safety and improving traffic operations through access modifications. Increasing the through lanes to two per direction would reduce congestion and the potential for related traffic crashes such as rear-end and sideswipe, same direction collisions. The introduction of curb, gutter, and raised medians consolidates access points and restricts turning movements at certain locations, thereby reducing conflict points and the potential for turbulence in the US 40 traffic stream. Provision of appropriate turning radii serves to concentrate heavy vehicles at selected intersections as appropriate and reduce conflict potential.

When this alternative progresses into the design phase, incorporation of safety strategies that have been proven effective at reducing the frequency and severity of crashes is recommended. The following strategies should be considered for inclusion in the design to address identified crash issues and enhance safety for motorists navigating through the study area:

- Non-dry Pavement – the following elements encourage drivers to slow down accordingly and maintain ideal surface conditions:
 - Changeable message signs to alert drivers about compromised road surface conditions.
 - Adequate drainage – pavement crown, inlets, and collection system for paved medians.
 - Skid-resistant pavement to improve tire friction.
 - Maintenance to clear snow from travel lanes.
- Lighting Condition – the following elements assist to illuminate the roadway during low light conditions:
 - Roadside delineators.
 - High-visibility pavement markings.
 - Signalized intersection lighting.
- Driver Guidance – the following elements assist driver navigation and reduce driving complexity:
 - Mast-arm mounted street name signs with appropriate text and symbol height at signalized intersections.
 - Advance intersection warning signs with supplemental plaques for cross street name.
 - Separate guide, regulatory, and warning signs to allow adequate distance and time to comprehend the messaging.
- Signalized Intersections – the following elements assist driver and pedestrian perception and optimize timing:
 - 12-inch LED signal lens.
 - Backplates with retroreflective borders for signal heads.
 - One overhead signal per through lane.
 - Side-mount signal heads on poles.
 - Countdown pedestrian heads.
 - Adequate yellow clearance interval timing to reduce red-light running.

7. Conclusions and Recommendations

This traffic study was initiated to analyze and make recommendations for the widening of US 40 from two to four general purpose lanes from the CR 5 intersection to the Rendezvous Road intersection. This is the first comprehensive effort to amalgamate proposed development-generated vehicle trips and proposed roadway network improvements in Fraser. The study resulted in forecasts for the expected traffic volume demand for the Saturday midday peak hour in years 2022 and 2045. A Saturday midday was selected to represent peak traffic conditions on US 40.

Based on approved development thresholds and background traffic growth, the ADT is expected to increase from 14,600 to 24,100 vehicles at the west end of the study area between 2019 and 2022, and from 18,800 to 30,500 vehicles at the east end of the study area. These are approximate increases of 62 percent (east end) and 65 percent (west end) in this 3-year timeframe. Development-generated trips account for approximately 94 percent of this volume increase and 36 percent of the total projected ADT at both ends of the study corridor in year 2022. Peak-hour volume demand increases are also expected at each intersection in the study area. For example, an approximately 50 percent increase is anticipated for the total volume demand through the CR 72 signalized intersection with US 40. Applying these forecasts to the existing and committed roadway network led to the conclusion that the planned widening effort is necessary to maintain traffic flow through the Fraser as early as year 2022.

Continued background growth and additional development result in year 2045 ADT projections that are nearly quadruple the 2019 counts. Development-generated trips account for 65 percent of this volume increase and nearly half of the total projected ADT at both ends of the study corridor. The analysis of the year 2045 volume forecasts with the proposed roadway network at that time projects that a 4-lane section for US 40 with signalized intersections and various auxiliary lanes will not accommodate the forecasted demand in year 2045. The forecasted ADT is less than the general HCM planning-level daily capacity of approximately 36,800 vehicles for a 4-lane roadway with left-turn lanes. However, the demand from the cross streets and the frequency of signals required to service them reduces the capacity threshold for this segment of US 40.

7.1 Short-term Recommendations

This analysis recommends the Year 2045 Refined Traffic Signals Alternative be implemented in the year 2022 or as soon as possible thereafter to accommodate the development anticipated to be complete in the near future. As described in the results section, this alternative includes the following improvements for US 40 and the signalized intersections:

- Widen US 40 to two lanes per direction between Rendezvous Road and CR 5. Extend the two westbound lanes far enough west of CR 5 such that the turbulence associated with the lane drop will not impact traffic operations to the east of the CR 5 intersection.
- Construct single left-turn lanes on each approach at every signalized intersection to the length required by the queuing analysis. Construct dual left turn lanes on the CR 72 north and south approaches.
- Construct an eastbound auxiliary lane between CR 72 and Old Victory Road, dropping this lane as a right-turn lane at Old Victory Road.
- Construct eastbound right-turn deceleration and acceleration lanes at the CR 5 intersection.

- Install traffic signals at the CR 5, CR 8, Eisenhower Drive, CR 72, and Old Victory Road intersections. Although not definitively known at the time this report was written, the analysis assumes the existing signal infrastructure at the Rendezvous Road intersection can remain in place with the roadway widening.
- Install crosswalks on the west approaches to the CR 8 and CR 72 intersections.
- Remove existing crosswalk on the east approach to the CR 72 intersection.
- Optimize the traffic signal timing for the year 2022 volume conditions to maximize throughput on US 40 while minimizing delay for the cross street and bicyclist/pedestrian movements. Design the signal timing to maximize progression opportunities for the US 40 through movements. Include the Wapiti Road intersection with CR 804 in the signal optimization and progression design.
- Design the signal timing for the CR 5 intersection to include interconnect with the railroad crossing. Also incorporate dilemma prevention timing with the use of advanced detection in the eastbound direction.

Consolidation of existing access points and lane configurations for the unsignalized intersections will be recommended upon completion of a subsequent effort by CDOT, the Town of Fraser, and Grand County to optimize traffic operations and internal circulation through Fraser. If funding does not permit full implementation of the short-term recommendations in one project, the following suggests a priority order for the recommended improvements:

- 1) Widen US 40 to include installation of the underground traffic signal infrastructure along with auxiliary and turn lanes. Install the new CR 72 traffic signal and crosswalks (no east approach) which were presumably in conflict due to the widening. The additional through- and turn-lane capacity is necessary to accommodate projected volume demand. This signal was programmed for replacement but was put on hold pending the outcome of this US 40 Fraser project. Thus, CR 72 should be the first new traffic signal installed in this study area.
- 2) Install the Eisenhower Road traffic signal. This road is the only access across the railroad in the Fraser downtown core area and is a primary route to the elementary school.
- 3) Install the CR 5 traffic signal. This intersection has the highest left-turn demand (the westbound to southbound left) of the remaining three intersections to be signalized. A traffic signal at this intersection will also serve as a visual cue to eastbound drivers that they are entering a built-up area and their movements will be subject to traffic control at intersections. Note that there is also left-turn demand at CR 8, but drivers can access traffic signal control at the CR 72 intersection if need be to assist with the left-turn maneuver. Finally, a traffic signal at this location would serve to meter traffic entering the downtown core area and help create gaps for the turn maneuvers between the cross streets and US 40.
- 4) Install the CR 8 traffic signal and crosswalk. Of the two remaining intersections to be signalized, this intersection has a higher left-turn demand than at the Old Victory Road intersection. The crosswalk will assist with connecting of the regional trail network.
- 5) Install the Old Victory Road traffic signal. This installation completes the short-term recommendations.

The analysis projects these recommendations will provide acceptable peak hour levels of service for the background traffic and traffic generated by the developments anticipated to be complete in year 2022. How far beyond year 2022 these improvements would accommodate traffic is dependent upon the amount of development that is completed and when the trips generated by it start travelling along US 40 and through the intersections.

7.2 Long-term Recommendations

The timing to implement the long-term recommendations is dependent upon the pace of development. After installation of the short-term recommendations, the following items are recommended for implementation to complete the US 40 improvements through study area:

- Construct the unsignalized, full-movement intersection with the Rendezvous Planning Area 14E access road to include left- and right-turn deceleration and acceleration lanes per the Access Code. This improvement is expected to be constructed by developers in conjunction with the adjacent development that is prompting this addition to the roadway network.
- Construct the south approach to the Rendezvous Road intersection with US 40 to include eastbound right-turn deceleration and acceleration lanes. This improvement is expected to be constructed by developers in conjunction with the adjacent development that is prompting this addition to the roadway network.
- Optimize the traffic signal timing for the year 2045 volume conditions to maximize throughput on US 40 while minimizing delay for the cross street and bicyclist/pedestrian movements. Design the signal timing to maximize progression opportunities for the US 40 through movements. Include the Wapiti Road intersection with CR 804 in the signal optimization and progression design.

As discussed in Chapter 5, Operations Analysis Results, the roadway network that results from implementation of the short-term recommendations and the development-driven long-term recommendations listed in the preceding paragraph is not likely to serve all the forecasted year 2045 peak hour demand. Therefore, the final long-term recommendation is to consider options to accommodate the excess demand to include alternative routes adjacent to US 40 at least through the length of the study area but ideally extending to the west and east of the study limits, a regional transit system or limitations to adjacent land use development and growth. Consideration of alternate capacity should ideally begin as soon as practical but no later than the completion of the short-term recommendations.

8. References

Byers Peak Properties. 2019. *Byers Peak Ranch Traffic Impact Study*. Prepared by Felsburg, Holt & Ullevig. May.

Colorado Department of Transportation (CDOT). 2019. *Combined Safety and Operational Assessment Report for US-40 MP 226.00 to 230.00*. CDOT Region 3. Prepared by Rich Sarchet, DiExSys, LLC. August 13.

----. 2018. *Traffic Analysis and Forecasting Guidelines*. Version 1. July.

----. 2015. *2040 Regional Transportation Plan*. Northwest Transportation Planning Region. February.

----. 2002. *State Highway Access Code Volume 2 Colorado Code of Regulations 601-1*. March.

----. n.d. "Traffic Data Explorer." *Online Transportation Information System*.

<https://dtdapps.coloradodot.info/otis/TrafficData#ui/1/0/0/criteria/040A/0/229/true/true/>

Cornerstone Holdings and Terracina Design. 2018. *Grand Park_Byers Peak Ranch Master Plan Illustrative 36X48 08192019.pdf*. December 3.

Cornerstone Holdings. 2019. *Grand Park/Rendezvous Annexation Agreement Entitlement (Density Chart)*. September 18.

Cornerstone Winter Park Holdings LLC. 2005. *Cornerstone Planning Area 1Wa Access Operations*. Letter to Jack Bestall from Lyle DeVries. Prepared by Felsburg Holt & Ullevig. March 29.

Cornerstone Winter Park Holdings LLC. 2013. *Grand Park Fraser, Colorado Second Edition Traffic Impact Study*. Prepared by Felsburg Holt & Ullevig. January.

Federal Highway Administration (FHWA). 2014. *Intersection Safety Strategies, Second Edition*. Office of Safety. September 4. Accessed January 18, 2020.

https://safety.fhwa.dot.gov/intersection/conventional/signalized/FHWA-SA-15-085_Strategies_2.pdf

----. 2012. *Manual on Uniform Traffic Control Devices for Streets and Highways*. 2009 Edition, Revised May 2012.

Fraser Development Company. 2019. *Transportation Impact Study for Roam (Formerly Beavers)*. Prepared by McDowell Engineering, LLC. Revised April 15, 2019.

Institute of Transportation Engineers. 2017. *ITE Trip Generation Manual, 10th Edition*. ITE TripGen Web-based App. <https://itetripgen.org/index.html>.

Ironwood Camp, Inc. 2016. *Arrow at Winter Park Traffic Impact Study*. Prepared by Felsburg, Holt & Ullevig. May.

Koelbel and Company & Cornerstone Winter Park Holdings LLC. 2004. *Rendezvous Fraser, Colorado Traffic Impact Study*. Prepared by Felsburg Holt & Ullevig. December.

M3 Property Service. 2019. *Auxiliary Turn Lane Assessment Transportation Impact Study for Riverview Townhomes*. Prepared by McDowell Engineering, LLC. May 28.

State of Colorado Demographers Office. 2018. "Grand County, July 2015." Colorado Population Estimates by County, 2010-2018. <https://demography.dola.colorado.gov/population/population-totals-counties/>

Town of Fraser. 2017. *2017 Downtown Fraser Strategic Plan*. Prepared by Community Builders.

Town of Winter Park. 2012. *US 40 Corridor Analysis*. Prepared by McDowell Engineering, LLC. Revised August 22, 2012.

Town of Winter Park. 2019. *Transportation Impact Study for Town of Winter Park Lift Operations Center*. Prepared by McDowell Engineering, LLC. February 12.

Transportation Research Board. 2016. *Highway Capacity Manual Sixth Edition: A Guide for Multimodal Mobility Analysis*.

Vogel & Associates. 2017. *Transportation Impact Study for Winter Park Mixed-Use Development South Sitzmark Parcel*. Prepared by McDowell Engineering, LLC. Updated April 27, 2017.

Appendix A

Traffic Count Data

Appendix B
Travel Time Data Collection Field Logs

Appendix C
US 40 Fraser – Existing Access Book

Appendix D

Vissim Calibration Process

Appendix E
Operations Analysis Results

Appendix F
Signal Warrant Analysis Volumes

Appendix G
Fraser Valley Parkway Assessment